

HANDLE DESIGN MAGAZINE

groë1

1

THE WORLD'S FIRST
HANDLE DESIGN
MAGAZINE



WE
JUST
MAKE
HANDLES

CHECK US OUT!





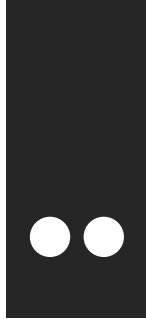

EATDESIGNSLEEP

WELCOME TO GROËL'S UNIVERSE

By designers for designers.

Discrete, contemporary and elegant.

117. Log.gic LEVER HANDLE DESIGN







ILLUSTRATION
Carmina G.
EDITORIAL
María Torregrossa

IL DESIGN

54 UTOPIA IN DESIGN



124

*Every great design begins
with an even greater story*

IBIZA COLLECTION
DESIGNED BY
Daniel Torregrossa

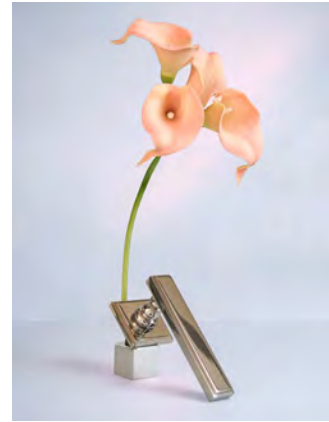

38 THE QUINTESSENCE OF DIVERGENCE

FOUNDATIONS

PHOTOGRAPHS **Carmina G.**
EDITORIAL **Vanessa Ruiz**

100 AT THE HEART OF BIMBA

COLLABORATIONS

DESIGNED BY
Gerard Sanmartí
from **Lagranja Studio.**



46 ESPUCH

COLLABORATIONS

DESIGNED BY
Toni Espuch
from **Azul Tierra Studio.**

140 DUALITY OF DESIGN

LA FABBRICA FINISHES

EDITORIAL
María Torregrossa

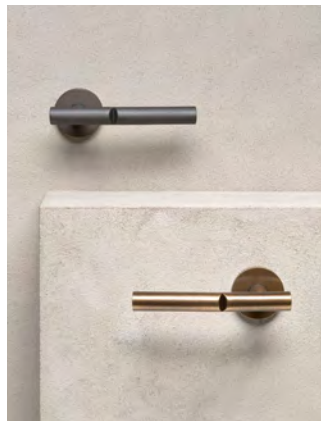

PHOTOGRAPHS **Michael Jackel**
DESIGNED BY
Pelizzari Studio

78
COLLABORATIONS

GESTURES HANDLE COLLECTION

114 JE T'AIME MA CHÉRIE

PHOTOGRAPHS **Jero Muñoz**
DESIGNED BY **Daniel Torregrossa**

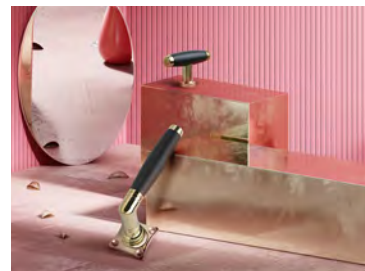



**mmm
tasty.**

0% SUGAR
50% PASSION
50% DESIGN

528. Otto LEVER HANDLE DESIGN

62 SOKOLNIKI

A TRUE STORY - the exogenous trigger. As you may have experienced, inspiration comes when you least expect it.

150 "LA FABBRICA"

Find out first-hand what the company's raw materials are and how they are handled to offer the best quality and finishes on the market.

131 THE FINISHES LAB

Discover how your favourite finishes are made straight from the lab.

146 FIRST CONCEPT, THEN DESIGN

Being present in more than 35 countries allows us to reach out to the most prestigious worldwide projects.

20 THE ORIGINALS

Groël's big three: the beginning of a new era. Our iconic models with unparalleled design and quality, striving for the highest standards to meet their customers' expectations.

69 LA BOUTIQUE DE LA BELLE ÉPOQUE

Have you ever seen how a handle is made from scratch? Find it out.

137 THE PINNACLE OF DESIGN

Black as the ultimate representative of glamour, that's a fact. Learn about the importance of this finish and how Groël was inspired to use it.

109 RUDE BUT CUTE

At Groël, the variety of existing styles and the desire to adapt to any environment led to the creation of rustic models in which, with brass as the primary element, the finishes and other materials, merge to create the perfect rustic handles.

28 THE EVOLUTION OF A CLASSIC

Following to the success of our most classic models we have allowed some of them to evolve without losing their essence.



10 L'INIZIO DI UNA GRANDE STORIA

Learn about the beginnings of Groël and what's behind a dream that came true.

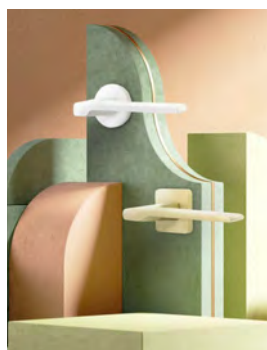

34 GROËL WORLD WIDE

Find out how Groël reached more than 35 countries with a quality and reliability seal.

118 MEET THE "CHEF"

We explain how Groël can offer you the best solution for your projects, either by supplying you with its flagship products or by designing a completely customised product.

GROËL'S FOUNDATIONS

1998

GENESIS

L'INIZIO DI UNA GRANDE STORIA





"Whatever you do, be different. If you're different, you will stand out."

Although Groël was founded in 1998, it has a much longer history dating back to the 1950s. The Torregrossa family has always been involved in the world of hardware and handles in several companies. José Torregrossa, Daniel & Carlos' grandfather, was known for creating the most important commercial networks in the Spanish peninsula and integrating the European market and its diversity into the Spanish industry. He would always be asked how he had managed to accomplish such expansion, to which he usually replied "you have to do things the right way, with passion, love and dedication- as they are meant to be done".

That sentence stuck into Daniel's mind and working philosophy bringing him to where he is today. He learnt that results came from believing in what you do and putting your heart into it, no matter what resources you have. Nonetheless, he quickly realised the limitations of working with this traditional industry: lack of diversity in design, deficiency in quality and the general uninspirational atmosphere.





“You can’t use up creativity. The more you use, the more you have.”

- Maya Angelou.

Finding the tedium of his career was the turning point in Daniel’s life, he did not just want to be different but make a difference. Sometimes striving is not enough to drive you to success, sometimes a fresh start outside of your comfort zone is what’s needed. During the summer of 1998, the birth of Groël took place. A new journey full of obstacles, fears and motivation to thrive.

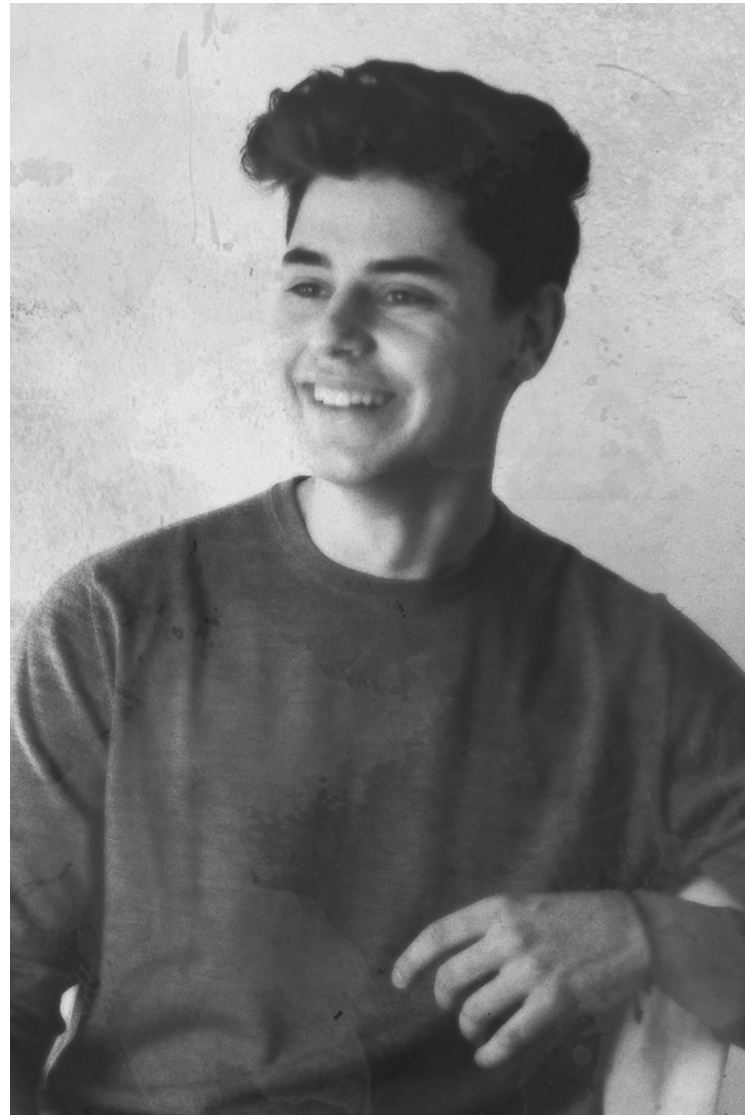



We tend to forget the relevance of **common objects** in our life that we use on a daily basis. However, when they don't perform properly we realise that our well-being depends on **small details**. This is when we start appreciating the fundamental **beauty** of **functionality**.

MEMENTO TORREGROSSA

GROËL'S MAGAZINE

**What's the origin and evolution of Groël's logo?
Why does it have a diaeresis?**

DANIEL TORREGROSSA

Well, it's actually very simple, it's the composition of the third syllable of my surname with the third syllable of my name: Torre(*gro*)sa Dani(*el*). The diaeresis was added for several reasons. At home I always spoke French with my mother, and it has been an important part of my life ever since. Furthermore, adding this "tréma" made Groël be phonetically identical to Italian and Spanish when read in French. Another reason is also its original aesthetic. I just purely liked the way it looked and it leaves room for creativity for marketing purposes.

As for the logo, I created it on my first Mac, based on the trending font at that time, the Comic Sans in capital letters. Nowadays it has become an



infamous font for designers, however at that time it did blow everything up. After developing more of my identity in the market I decided to represent it better. Hence, I completely changed the philosophy behind the logo. I wanted to express elegance and design, but without losing originality. This is when I selected the Century Gothic font and decided to put the whole logo in lower-case. This font enhances the height of lower-case characters and is reasonably purely geometric design closely based on the circle and square. It also has less variation in stroke width than fonts designed for small sizes tend to show and a relatively slender design in its default weight. Lastly, the most recent modification of the logo was separating the œ which in French œ is called "e dans l'o" [ə dâ lo], which literally means e in the o and removing the bold in it to give minimalism to the logo.

GROËL'S MAGAZINE

Why did you create Groël?

DANIEL TORREGROSSA

I was and still am a person with a very clear vision on how to do things in order to obtain the best possible result. I was seeing clear gaps in the handle industry in Spain. The designs and finishes were traditional and hadn't evolved for years. During the 90s, the population was very closed



KODAK PORTRA 400

43

KODAK PORTRA 400

KODAK PORTRA 400

43

KODAK PORTRA 400

KODAK PORTRA 400

43

KODAK PORTRA 400

KODAK PORTRA 400

KODAK PORTRA 400

KODAK PORTRA 400

minded in this area of design and the quality of the hardware was below standards and I kept telling myself that better quality had to exist somewhere.

GROËL'S MAGAZINE

What's the story behind the *Made in Italy*?

DANIEL TORREGROSSA

In the late 90s I decided to follow my own path and develop my personal ideas to their fullest. I was already very experienced in lever handles since I had been working for a decade in this field, but now it was time to go in a new direction with new concepts. In order to do so, I had to travel to the country of design, I had to become "made in Italy". Italy at that time was already much more advanced and felt like were on the same page and my concepts were understood.



RTTRA 400
43
KODAK PORTRA 400

GROËL'S FOUNDATIONS



GROËL'S MAGAZINE

What gave you strength to continue with your life project?

DANIEL TORREGROSSA

I couldn't have done it without my Brother's inclusion to the company and my wife's support. Starting a solo journey is what's meant to happen when your ideas do not fit within society, but it comes to a point where you can't keep up by yourself, and you carry too much on your shoulders. The arrival of my brother did not only relieve that weight, but also helped the company's business network to grow and expand to where it is today.



KODAK PORTRA 400

GROËL'S MAGAZINE

**What was the first model you designed?
Was it successful?**

DANIEL TORREGROSSA

As a kid I was always very creative and enjoyed my free time doing paintings and drawing. I never designed a product as such before, but being aware of my artistic capacity I was confident in taking the risk to design something innovative for that time. This is how the model 117 Log.gic was created. This handle presents an ingenuous style with straight lines but with subtly rounded profiles.

I presented this model in Spanish factories where it was declined since minimalism and contemporary design wasn't a thing at all - Spain was more into the rustic style. This rejection gave me strength to pursue my idea, it proved that I truly had a different perspective, which I believed was a positive attribute. After a lot of investigation and a lot of work I managed to finally manufacture in Italy. Nowadays, 25 years later, the 117 Log.gic handle is still among our top 3 best-sellers gaining international recognition. This is the model that broke the barriers of time.

GROËL'S MAGAZINE

What was your next step?

DANIEL TORREGROSSA

We soon understood we had to continue our journey creating, learning and innovating. This is when we created both 803 María and 133 Hélice lever handles. The María handle is more of a rustic style adapted for the Spanish market which has also gained success and is nowadays still the protagonist of several projects. The 133 Hélice handle is more of an ergonomic model presenting a modern and advanced curvature - which has also attained significant projects.

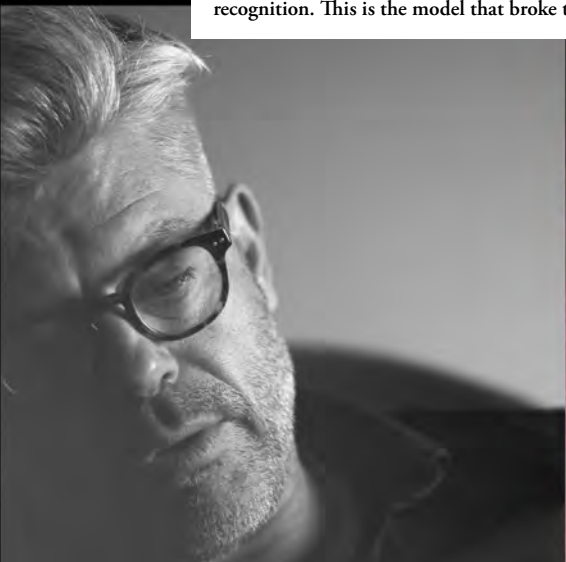
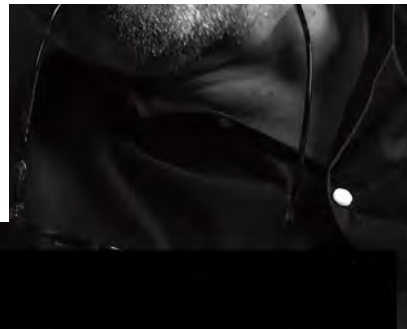

KODAK PORTRA 400
43
H



A GREAT BEGINNING GROËL'S EVOLUTION

The company that revolutionised
the art of handles

At the beginning of Groël's career in the world of handles, design and the desire to innovate by creating something different and of high quality was the maxim to follow. It is for this reason that among Groël's original models we find classics that end up being reinvented over time.

DANIEL TORREGROSSA



#01



Firstly, we see that the handle was the main image of the logo, leaving the name in the second place.

#02



The construction of the logo evolved providing value to the brand itself. We opted for a typographic construction with the linguistic ligature œ.

#03



Finally, this would be the first version of the actual logo.



WELCOME TO YOUR WELL-BEING RETREAT

133. Hélice LEVER HANDLE DESIGN



CAP VERMELL GRAND HOTEL
MALLORCA



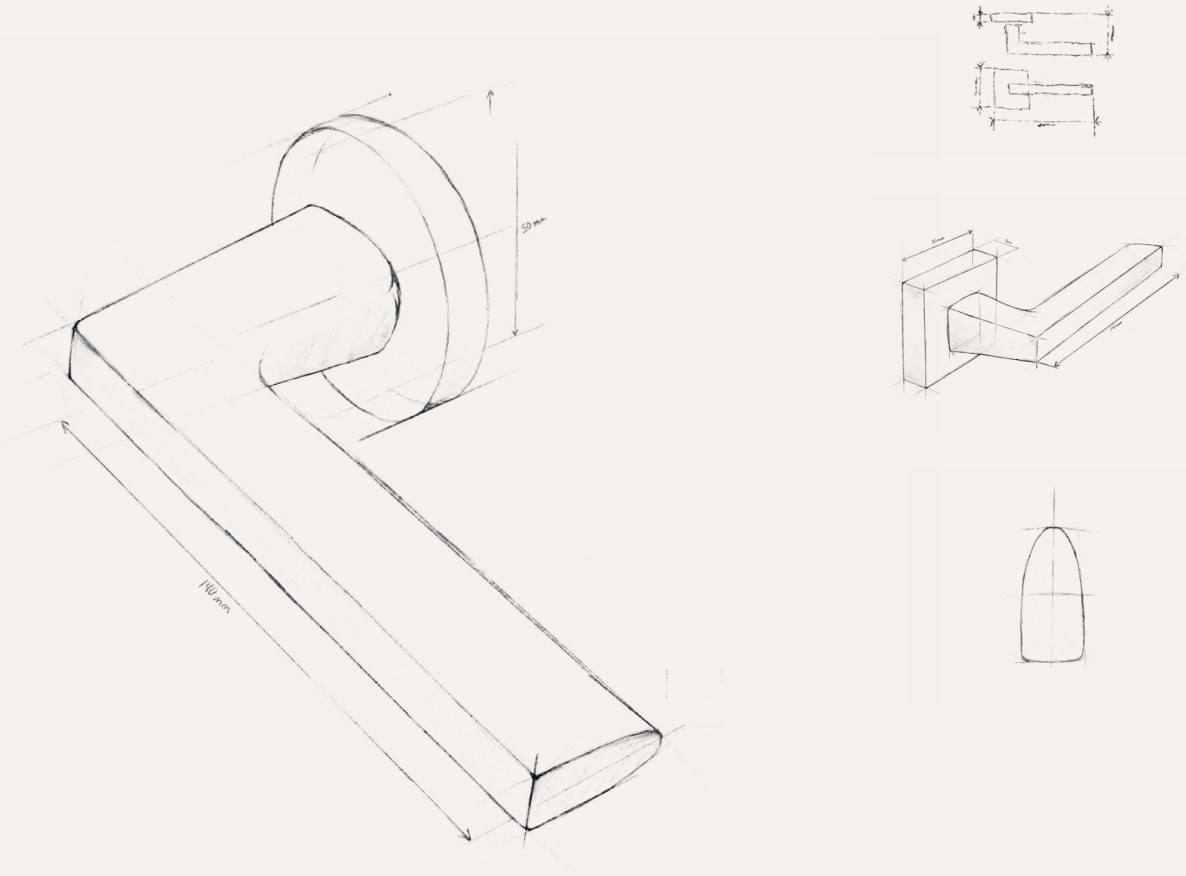

The design that broke the barriers of time.

Nowadays, 25 years later, the Log.gic lever handle is still among our top 3 best-sellers gaining international recognition.

Daniel Torregrassa

Log.Gic

Minimalism first



117. LOG.GIC LEVER HANDLE

Forged in pure Italian brass, this lever handle presents a **timeless style with its firm structure composed by straight lines**. Its subtly rounded edges make it blend perfectly into any space.

This design will give a minimalist touch to your interiors and can be adapted to many different formats: round or squared rose, oval or rectangular backplate and oval or rectangular window mechanism.

In addition, **this design includes matching accessories from the same collection such as a pull handle** that can be applied to sliding doors, wardrobes, drawers, and any kind of furniture.

All our products are associated with their escutcheons, privacy turn & release and door stops from the same style and finish. The **Log.gic** model can be produced in virtually any finish you desire. As a starting point we propose our range of trending finishes such as **black, graphite and satin brass**.

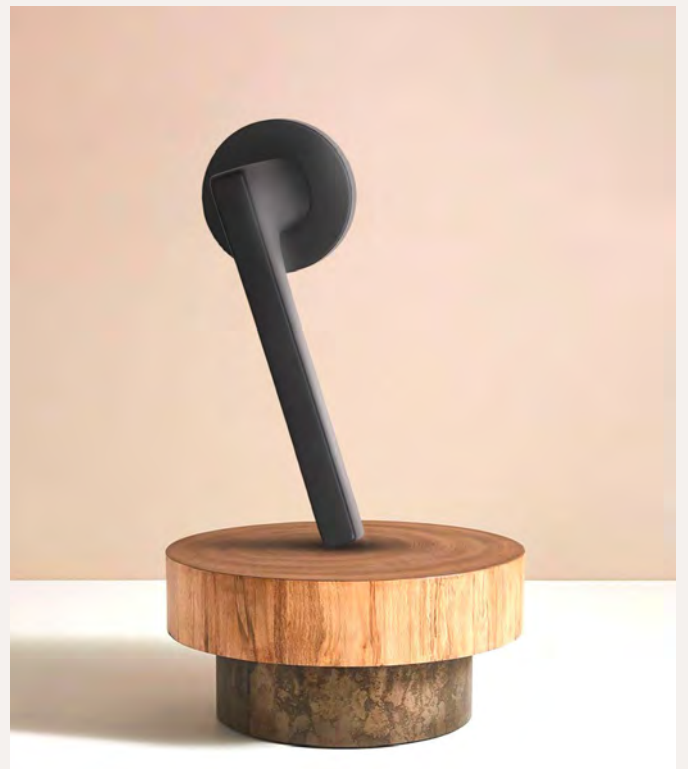

827M. LOG.GIC PULL HANDLE

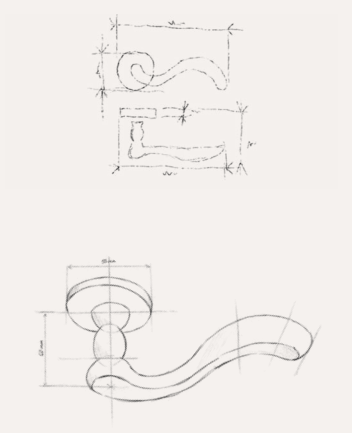
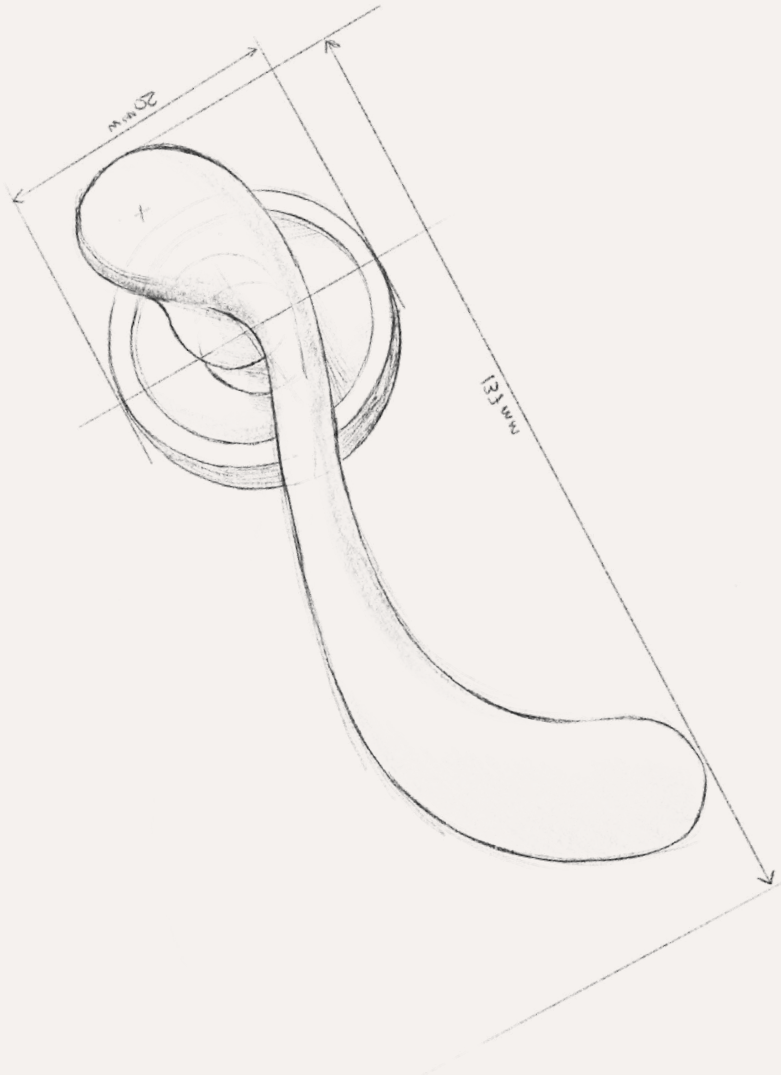

A design that makes tradition.

The María lever handle is more of a rustic style adapted for the Spanish market which has also resulted into in success and still nowadays is the protagonist of several projects.

Daniel Torregrossa

María

The Spanish flavour



803. MARÍA DOOR HANDLE

A Spanish classic allied with **the nature of beauty and good taste**. The strength of pure brass sweetened by the gentleness of a curve. This handle is a perfect fit for rustic environments.

The focus for rustic interiors is to create a relaxing atmosphere by highlighting the use of wood, stone, leaves, and other organic elements. Instead of worry about perfect lines, **rustic allows the character of each piece to stand out**.

Therefore, we accordingly propose a range of finishes: **antique brass, bronze, fumé, effetto ferro, and polished brass**. Furthermore, *María* handle also presents matching accessories from the same collection such as a pull handle that can be applied to sliding doors, wardrobes, drawers, and any furniture.

All our products are associated with their escutcheons, privacy turn & release and door stops from the same style and finish.



810M. MARÍA PULL HANDLE

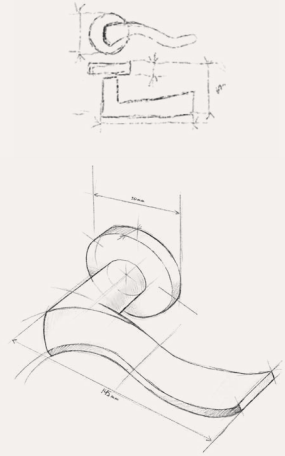
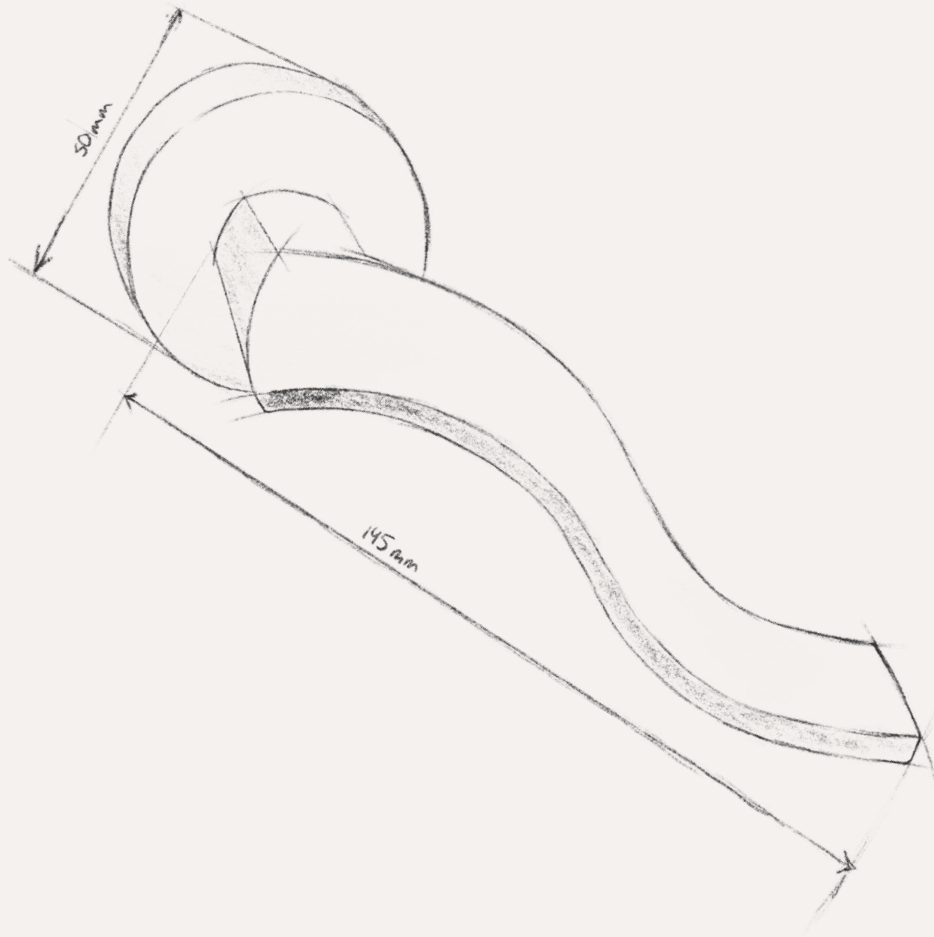

Equally ergonomic and beautiful.

The Hélice lever handle is more of an ergonomic model presenting a modern and advanced curvature - which has also attained significant projects.

Daniel Torregrassa

Hélice

Landing in harmony



133. HÉLICE LEVER HANDLE

Inspired by the shape of a helix, the meticulous combination of this handle's planes and curves results in a single purpose, design excellence. Without losing any of its splendor, the flat curvature of this handle creates the perfect surface allowing the hand to rest comfortably on it. This **ergonomic lever handle** revolutionised the manufacturing industry.

For this contemporary handle, we propose **golden or silver finishes** combined with a polished or satin surface texture.

You can chose your format and combine it with matching escutcheons, privacy turn & release and door stops from the same style and finish. Furthermore, **this handle design also presents matching accessories such as the 235M Torso** pull handle that can be applied to sliding doors, wardrobes, drawers, and any furniture.



235M. TORSO PULL HANDLE

Originals



CUBE DOOR STOP
BLACK



MARÍA BACKPLATE
FUMÉ



HÉLICE WINDOW HANDLE
POLISHED CHROME



LOG.GIC BACKPLATE
BLACK



CONTEMPORARY YALE ESCUTCHEON
POLISHED CHROME



SLIDING DOOR KIT
FUMÉ



RUSTIC TURN & RELEASE
FUMÉ



LOG.GIC WINDOW HANDLE
BLACK



LISA CABINET KNOB
POLISHED CHROME

*The Originals Collection can be combined with these accessories
and many others available in our online catalogue.*

Available in different
formats

Round rose
Pull handle

Backplate
For window

Available in different
finishes

Matt black
Polished nickel
Polished brass

vasilisa

vasilisa

vasilisa

vasilisa

A cylindrical artful
conception with a
romantic hint.

Rounded profiles and
romantic lines.

This handle meets the
golden rule of quality
design: minimalism.

Designed to create
relaxed environments.

We design and manufacture our new products with the greatest passion, but we also recognise that what works must be preserved.

WRITTEN BY **Vanessa RUIZ**

PRODUCT DESIGNER

Daniel TORREGROSSA

At the beginning of Groël's career in the world of handles, design and the desire to innovate by creating something different and of high quality was our goal. It is for this reason that among Groël's original models we find classics that end up being reinvented over time. Today, Groël has a wide range of lever and pull handles in different styles that have been created following the concerns of our designer, adapting to the needs and preferences of the market. However, the first steps of this company were firmly committed to innovative, clean and sober designs, with smooth profiles and pleasant to the touch. This is what imbues hints of Italian design to any room, standing out for its minimalism - as strange as it may sound.

Against this backdrop, we witnessed the birth of the Fila design, a model that combines a rectilinear, thin and smooth surface on its grip with a slight volume on its lower part that blends in its neck. A novel concept bursting into interior design like a breath of fresh air. This modern and original handle became one of Groël's best-sellers, which, despite its simplicity, remains highly appreciated.

Over time, customer preferences and market needs have changed. In addition, our unceasing restlessness, our passion for design and our inexhaustible will for progress, propelled us to create new models and new ways to reinvent ourselves without leaving aside our essence that defines us.

However, if there is one thing we cannot deny, it is our respect for our flagship models. Those designs that have made a difference and that our customers around the world have loved so much. It is for this reason that classics like the Fila model have not only remained in our catalogue among our top sellers, but have also evolved.

This is the birth of the Special handle design: a model with a stylised silhouette and unparalleled purity, the evolution of a classic, the definition of a profile towards the sublimation of its initial design. The pronounced and abrupt volume of the Fila neck is softened by creating a subtle curvature of great elegance and delicacy, while at the same time lengthening the handle's grip. If Groël is synonymous with design, quality and style, the flagship model that fulfills these same premises is undoubtedly the Special handle. We therefore find the same concept represented by two handles, one with a more robust appearance, with more presence and strength, and the other more delicate, more subtle and elegant. Thanks to this stylistic bifurcation of common origin, we can corroborate the versatility of Fila and Special. These models have the ability to fit in any home and environment depending on the spatial and decorative importance that you want to give to the handle.

Given the success of our classic models and the dedication we put into their creation, we consider it necessary for them to remain in our catalogue. Nonetheless, we also allow them to evolve towards the creation of new designs without losing their essence, Groël's essence.

THE EVOLUTION OF A CLASSIC

FROM FILA TO SPECIAL

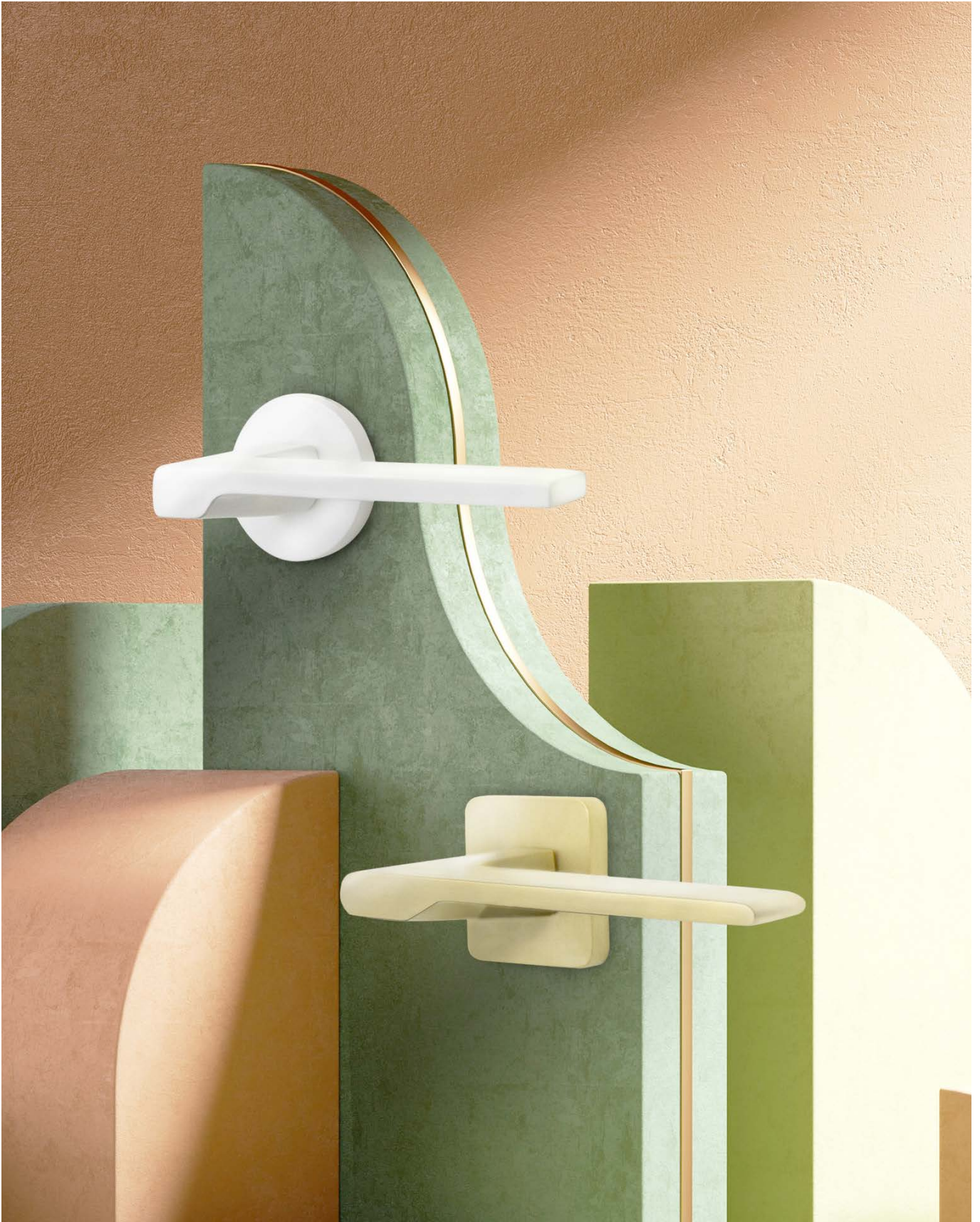

147 FILA

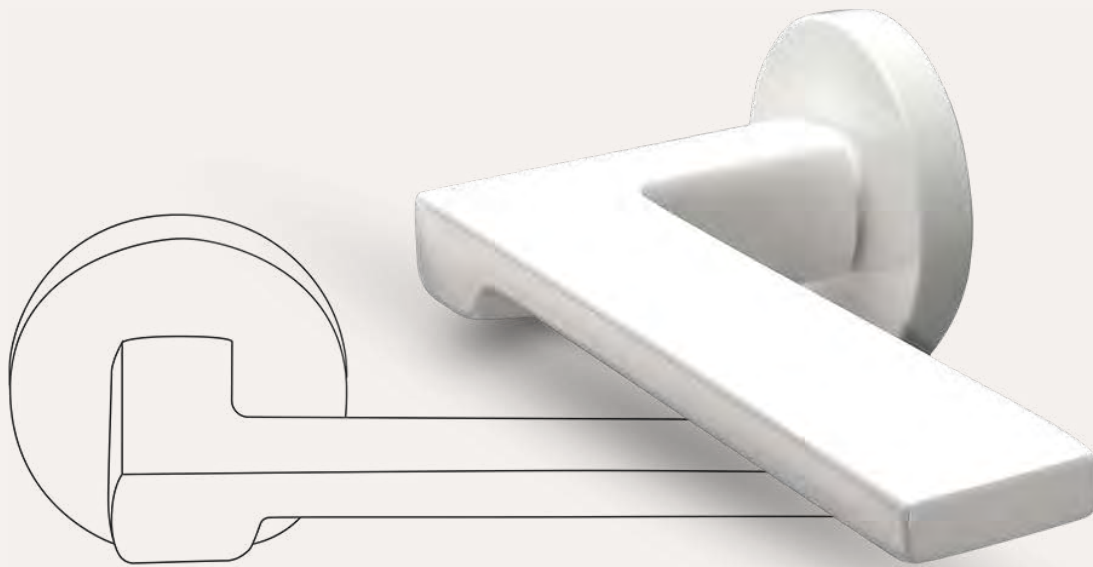

Fila



It all started with this handle design exclusive to Groël. Popular for its originality in design and based on a unique idea and a concept. **The Fila lever handle**, a model that combines a rectilinear, thin and smooth surface on its grip with a slight volume on its lower part that blends into its neck. Made in pure Italian stamped brass, **this novel concept is bursting into interior design like a breath of fresh air.** This model in round rose is very trendy especially in a black finish.

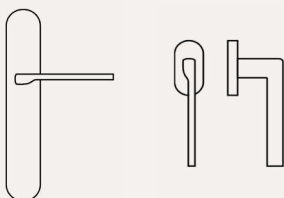

BACKPLATE
147P FILA

WINDOW HANDLE
147G FILA

Furthermore, this handle design also presents **matching accessories from the same collection** such as a pull handle that can be applied to sliding doors, wardrobes, drawers, and any kind of furniture. All our products are associated with their respective cabinet knobs, escutcheons, privacy turn & release and door stops from the same style and finish.

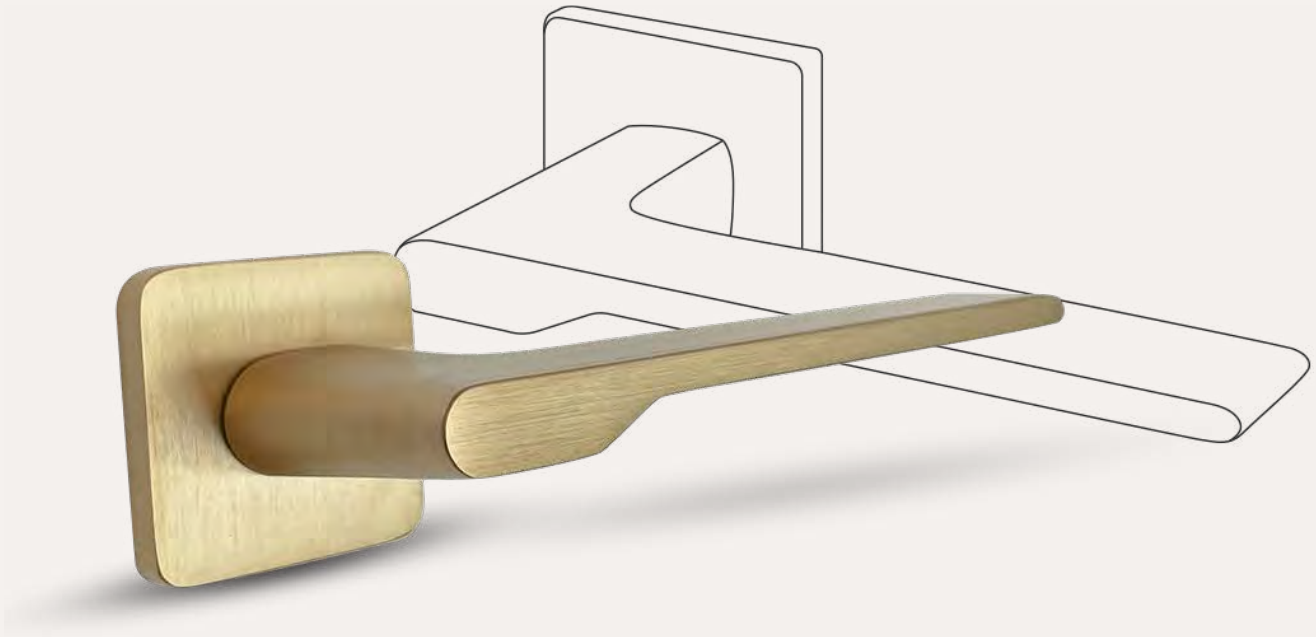

Special



An insignia model with a stylised silhouette and unparalleled purity, the evolution of a classic, the definition of a profile towards the sublimation of its initial design. The pronounced and abrupt volume of the Fila neck is softened by creating a subtle curvature of great elegance and delicacy, while at the same time lengthening the handle's grip.

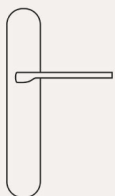

BACKPLATE
247P SPECIAL

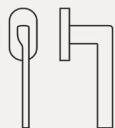

WINDOW HANDLE
247P SPECIAL

Exclusively made in pure brass this flagship model has been awarded its own rose matching its profiles, squared but round, minimal and sophisticated. All our products are associated with their respective **cabinet knobs, escutcheons, privacy turn & release and door stops from the same style and finish.**



809. **Kilto** LEVER HANDLE DESIGN

952. **Ducato** CABINET KNOB DESIGN



An interior
is the projection
of the soul.

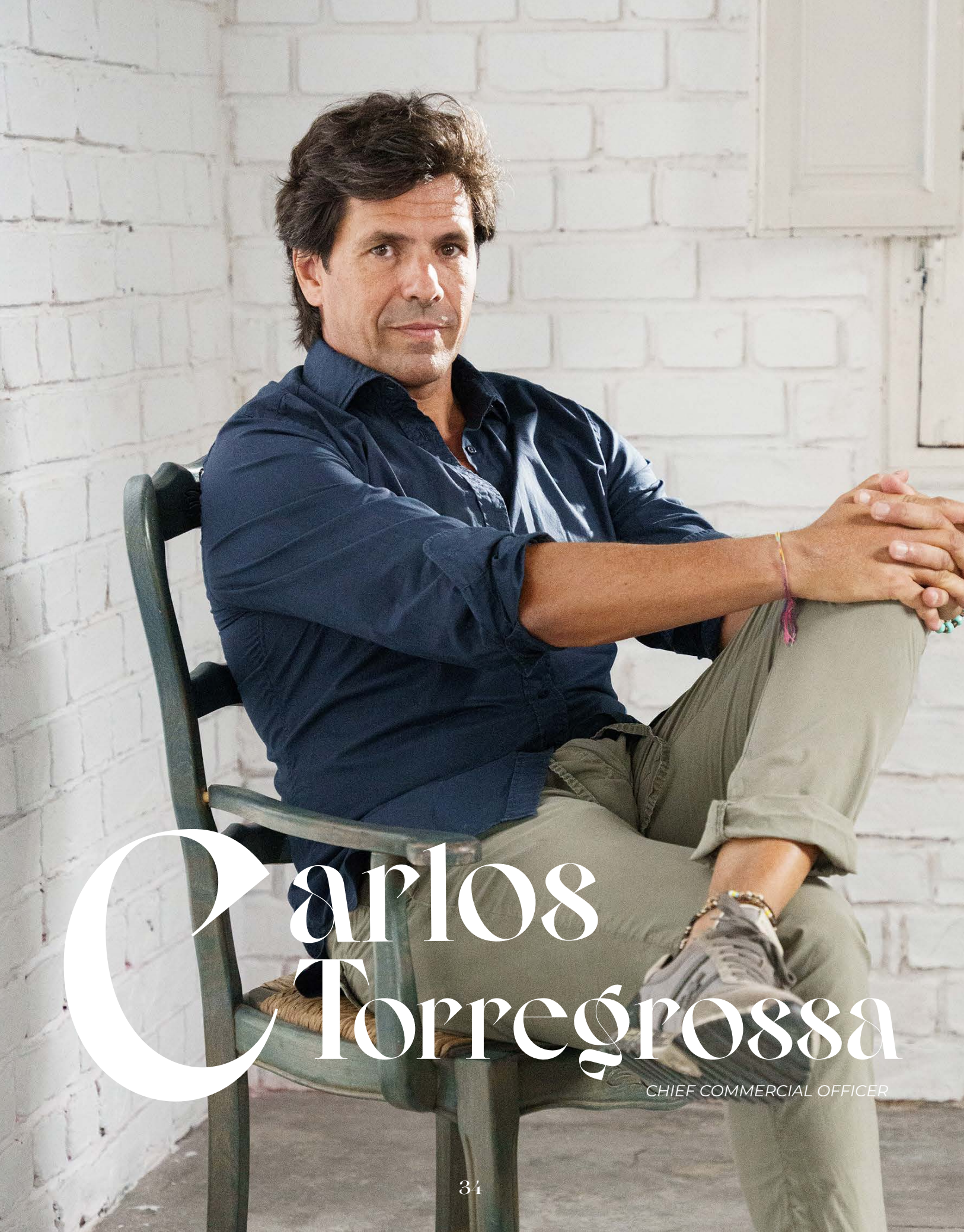

Carlos Torregróssa

CHIEF COMMERCIAL OFFICER

“My goal is for Groël to be the world’s leading brand in quality, reliability and proximity.”



GROËL'S MAGAZINE

How did you first start in Groël?

CARLOS TORREGROSSA

My beginnings were halfway between the family business, as a salesman, and Groël. The customer profile was the same, so I took advantage of the experience and knowledge acquired to project Groël in the best possible way. Customers who were very confident in our good work and reliability, opened their doors to us and trusted us and our product from the very beginning. Our first areas of influence were Alicante, Valencia, Castellón, Murcia and Albacete. From there, we expanded as we became well established and had the ability to serve new regions, until today, where we have reached 35 countries.

GROËL'S MAGAZINE

How has Groël evolved throughout your career?

CARLOS TORREGROSSA

On the one hand, Groël is always evolving thanks to the foundations on which it was created: transmitting our passion for what we do, our commitment, the product quality and our service. But something very important that has brought us to where we are today, is our technical and commercial know-how, and our ability to adapt to the needs of our customers.

On the other hand, it is always important to be able to manage the situation of the market and the sector in every aspect. For this reason, being aware of the evolution and situation of any distributor or manufacturer of handles is irrefutable, regardless of the range: imported from Asia, exported from Europe, lower, medium or higher range handles. Furthermore, knowing their different qualities and production processes is also helpful, as well as common mistakes or inaccuracies, in order to improve oneself. This has made it very clear for us that the future lies in maximum quality and that we have to be constantly innovating in order to be the best. The result is that, as I said at the beginning, we are constantly evolving.

GROËL'S MAGAZINE

What have you learnt from your career in Groël, both professionally and personally?

CARLOS TORREGROSSA

Professionally, every day is a new experience from which you learn something. Every market is different, so this is something that enriches you a lot. If, for example, each region of Spain is different (different way of thinking, different needs and styles), imagine each country (different fixing systems, tastes and cultures). Although our commercial policy is very clear and defined, the way of negotiating with each one is different and I love this. Another thing that has impacted me personally, is the opportunity Groël has given me to travel a lot and to meet many people from places that many would dream of going to, and to share experiences and cultures... And this is so enlightening!

GROËL'S MAGAZINE

How would you describe Groël today?

CARLOS TORREGROSSA

We are constantly growing, and we are actually consolidating the digitalisation of our company. This is making us progress even more and reach places we didn't reach before. It opens up many business opportunities for us, such as Contract, which we were already working in and where we are growing a lot. Our tendency is to go one step further. Not only, as I said before, to understand the needs of a client or carpenter but also those of a technician, an interior designer or an architect. As we are placed in a premium sector, the demands are much higher than in a standard sector. In today's premium projects, specialists are seeking harmony and excellence, to ensure that the finishes are integrated and that everything has the same meaning. We are very conscious of this need or way of approaching decoration, which is why, for many years now, we have been getting closer to this type of professional and we maintain a very close relationship through our service. This is how we manage to help customers, even going as far as customising pieces that are not in our catalogue to offer them a completely personalised service, covering their needs and making them feel comfortable with our brand and the way we treat them.

GROËL'S MAGAZINE

What are your short and long term aspirations for Groël?

CARLOS TORREGROSSA

We are in the process of internal improvement with the implementation of a new ERP that will help us to be much more reactive, improve our service both sales and after sales, and also an improvement in logistics by automating many processes of storage and preparation of orders. Investing in improvement only brings satisfaction. We always have projects on the go all over the world. We have created a great marketing team that is driving us forward, and that is going to take us very far. This project in such a booming market as visual communication, advertising, etc. is never-ending. It is constantly being developed and updated, which makes our company always "alive".



GROËL'S MAGAZINE
Is Groël sustainable?

CARLOS TORREGROSSA

We are the leading brand investing in ecologic technology. We maintain an environmentally sustainable production model because we do not conceive product or design quality without sustainability. Groël complies with the actual European environmental legislation and as well with the Sustainable Development Goals set for 2030. Nonetheless, our definition of sustainability is deeper than this comprising a wider spectrum with more values.

As Roberto Monti claims, “a brand with healthy values must operate with environmental responsibility, product quality and people’s wellbeing at its heart, being the employees, suppliers or clients”. At Groël, we agree with this statement in every aspect from people sustainability to product sustainability. We value our people to the highest standard and we like building a solid team because without every single one of us, this project would not be possible.

Moreover, it is important to highlight the bond between sustainable and timeless concepts to talk about product sustainability. For us, it’s unimaginable to design products only for the sake of fast fashion and trends that quickly decay, requiring an unsustainable manufacturing approach. This is why we dedicate so much time, creativity and thought to every single one of our creations. Sustainability is having a sustainable design by all means: a timeless aesthetic design, environmentally friendly production steps and shipping system, and an end product with a long life.

When creating products, we need to think of models that look contemporary yet at the same time inspired by the past. This is an ambitious path that may not always be practicable, but we try to guide our clients to choose spatial and furnishing solutions that they will never tire of as time passes. It is important to believe in the timeless concept just as we believe in sustainability since they go hand in hand. This is the basis of everything in Groël.



There is no quality if there's no sustainability.

The quintessence of divergence



Groël
never sleeps

Blooming
GROËL DIVERGES FROM WHAT
HAS BEEN WRITTEN UNTIL NOW.

Sometimes, everything that escapes from the norm, from what is pre-established or standard, what is divergent, has been branded as rebellious or imperfect. But sometimes, it is not a bad thing to break the rules to let your imagination and creativity run freely. Groël's philosophy dances between classic and contemporary, between traditional and avant-garde, and is driven and inspired by fashion, culture, dreams, a latent multiculturalism and design.



Groël flourishes through its divergent character. While 3D printers have taken over wood carvings, Groël maintains them. Every model is born from its pencil sketches and wood carvings to create the highest quality handles. Despite this traditional and artisanal *modus operandi* in the purest Italian style, the designs are innovative from the outset, creating the latest trends in the market. The first approach in Groël's genesis was creating bold designs with a minimalist character, taking this trend to its peak in later years with the Atelier collection.

Metamorphosis

The word Metamorphosis, from the Greek meta (after) and morphe (shape), implies an evolution, a change and a transformation. Groël has evolved, mutated and matured from its beginnings to the present day in many ways and has no intention of stopping. Some of its flagship models have remained intact due to their international impact and recognition, but others have evolved to very advanced designs. We are also witnessing a stylistic mutation through the creation and launch of the Atelier collection, which is stately, rococo, splendid and different from anything Groël used to create.

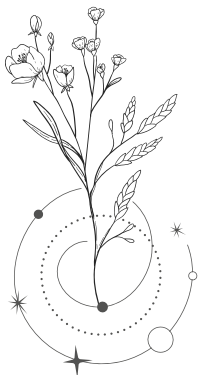

GROËL WORLD WIDE

This curiosity for design and this ambition to reach every home and space, meeting the expectations of any customer profile, also led to the birth of other models through the creation of the new contemporary handles, seeking other profiles, other silhouettes and shapes but keeping their elegance.



THE ESSENCE DREAMS IT LIKE A DREAM OF SHAPES. THE SHAPES FADE AWAY, BUT THE ESSENCE STAYS, DREAMING NEW DREAMS. MAN GIVES NAMES TO THESE DREAMS AND BELIEVES HE HAS CAPTURED THE ESSENCE, WITHOUT KNOWING THAT HE IS INVOKING THE UNREAL.

-Roger Zelazny



We talk about transgression when established structures are broken, when what is considered normal, acceptable or ordinary undergoes a metamorphosis and ends up being divergent. The Groël aesthetic is transgressive, it is daring, it is novel and its intention is to never cease to be so.

Thus, we find iconic models that comply with these three evolutionary premises, as is the case of the *Flow handle*, with its robust neck and delicate grip, rounded edges and timeless style endowed with a simple beauty. In addition, together with this handle, its own matching rose was created from a square shape with rounded edges, fitting both pieces, handle and rose, in a perfect visual harmony.

On the other hand, we find the *Roby handle*, with a cylindrical neck combined with straight lines sweetened at the ends escaping from abrupt angles, creating a combination of a clean, impetuous and noble profile. It is not an ordinary handle, no matter how minimalist it may be, every detail makes the difference.

Finally, the *Malika handle* perfectly embodies Groël's metamorphosis, the divergent character of his creations and the transgression of his models. Its staggered rose with its pronounced angles and squared shape combines perfectly with the rectilinear grip of the same style. It is united in the most original possible way by a turned neck, as if it had been formed by fusing spheres of different diameters to create an unparalleled harmony. A surprising handle designed to create passions, because without love and obsession there can be no creation.

Transgression

237 Flow

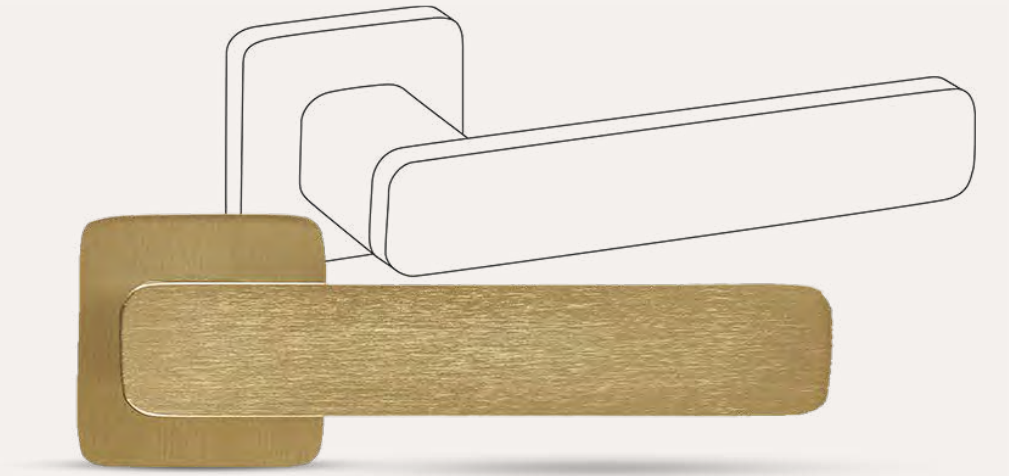

237 Flow

Technical, evolved & functional

Functionality is not always beautiful, but **what is beautiful is always functional**. That is why we firmly believe that beauty has the power to enhance anyone's lifestyle.

The Flow handle is a fully functional futuristic design and capable of reaching the most advanced interiors with its high quality owed to the pure brass. The combination of robustness and nobility, give this handle a minimalist expression without losing any of its elegance.

This handle has been given a **personalised rose, as an embellishment for its soft edges**. The **R4C rose** is exclusive to this design bringing the combination between a round and a squared rose.

This model **can also be set with its complementary 217M Sketch pull handle or assembled in other formats** (backplates and window mechanisms). We propose a **wide variety of finishes** for these handles as a starting point, from graphite to satin brass - however feel free to leave room for your imagination!

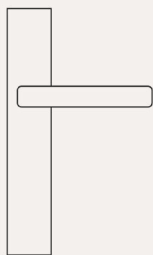

BACKPLATE
237PC FLOW

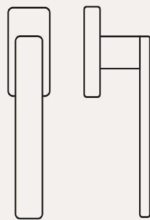

WINDOW HANDLE
237GC FLOW

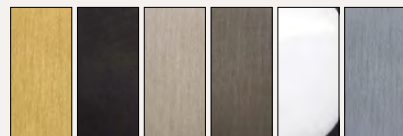

570 Malika



570 Malika

A contemporary design of a classic

We can't talk about creation without a great deal of love or obsession. Malika's harmony of consecutive lines and **its detailed neck make it a brilliant design.**

With its **artd co style**, this handle will become the protagonist of every vanguard interior. Made in pure Italian forged brass, this **atelier handle is very popular in polished finishes** which highlight its beautiful structure even more.

We embellished its squared rose, as well as its backplate version, with a subtle and unique **gradino design**. After choosing the format you desire you can combine it with matching escutcheons, privacy turn & release and door stops from the same style and finish.

This handle design is complemented by its 570M Malika pull handle giving a delightful touch to your kitchen, wardrobes and any furniture.

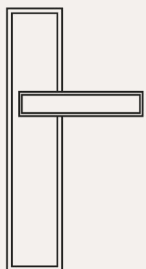

BACKPLATE
570PC2 MALIKA

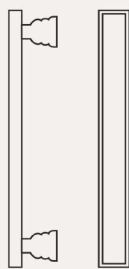

PULL HANDLE
570M MALIKA

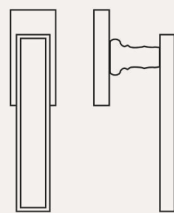

WINDOW HANDLE
570GC MALIKA

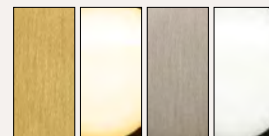

812 Roby

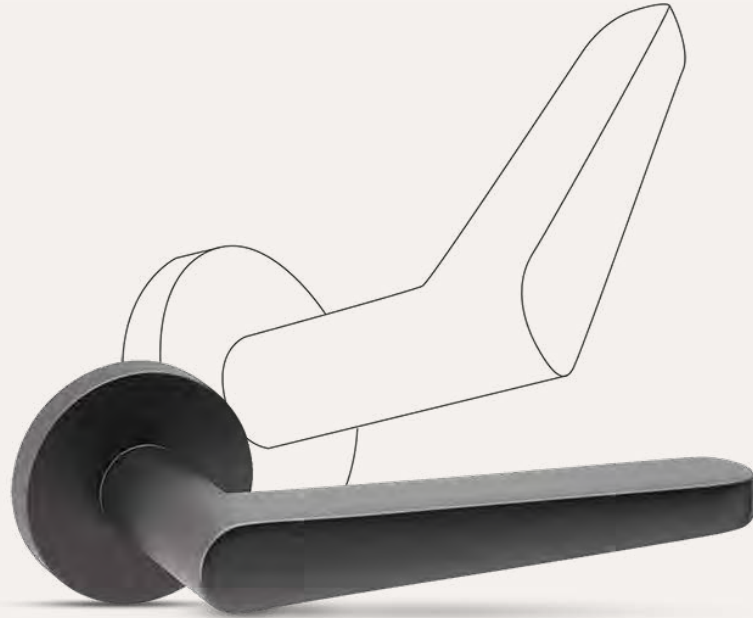

812 Roby Indulgence and confluence

Roby, the living icon. Let's take a look at the details of this design.

Starting from its mellow neck which quickly melts into a smart univocal roundness by all means. **The convergence of its lines is an absolutely exceptional and genuine touch**, adapting this handle to any type of environment.

If you fancy a more classic and serious interior just delve into our finishes to give a different personality to the same design.

Combine the Roby model with its different formats (round rose, backplate, window mechanism) to have them matching throughout your interiors. We suggest combining our **827M Log.gic pull handle** with the Roby door handle design for the Roby door handle design for a perfect complementary finish, check it out!

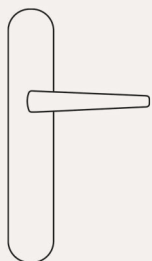

BACKPLATE
812P ROBY

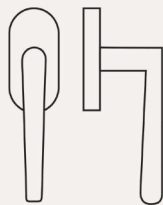

WINDOW HANDLE
812G ROBY

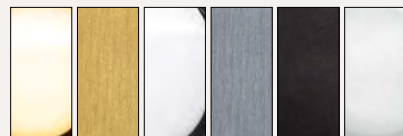

Divergent



FLOW TURN & RELEASE
SATIN BRASS



ROBY WINDOW HANDLE
BLACK



MALIKA BACKPLATE
POLISHED NICKEL



FLOW BACKPLATE
SATIN BRASS



MALIKA PULL HANDLE
POLISHED NICKEL



SLIDING DOOR KIT
BLACK



DUCATO CABINET KNOB
BLACK



SKETCH PULL HANDLE
SATIN BRASS



ATELIER YALE ESCUTCHEON
POLISHED NICKEL

*The Divergent Collection can be combined with these accessories
and many others available in our online catalogue.*

Space is the breath of art

We make tailor-made projects.

Let it flow

groëel
handle design

ESPUCH.

He's talking

TO
US

GROËL'S MAGAZINE

**What drives your creative process?
How did everything start?**

TONI ESPUCH

I think you are born with something, but later you develop it, don't you? Azul Tierra was born in Alicante 27 years ago because of my pursuit of beauty and objects, natural things and know-how. I love every noble material, everything that is handmade, and everything that goes through a manual process. I was working at a friend's shop for 6 years and I learnt a lot with her. Then I found the shop in Alicante and I fell in love with it. I started at a very young age, when I was 23, and since then, every day has been a continuous search for beauty. The more you do, the more freedom and creativity you reach to develop things. In the end, Azul Tierra began with a child's enthusiasm with objects and anything really that I had access to. Because of my desire to have knowledge, to learn and to get to know everything, I have travelled to many fairs of all kinds: textile, antiques, art... I have travelled to many parts of the world investigating and gaining knowledge... For me, every time you travel or read a book, see a film, or anything else, it makes you look at things and question why things last and why they don't. When I saw that I needed to grow a little more, I opened another very beautiful store in Barcelona, so it was a bit like growing up and feeling stronger to generate more.



GROËL'S COLLABORATIONS





GROËL'S MAGAZINE

What do you consider important when starting any kind of project?

TONI ESPUCH

In the world of interiors, what is important is to make a house personal. It has to be comfortable, it has to feel great to be at home, it has to be very cosy and you have to be surrounded by objects that really fulfil you and have a use for you. Azul Tierra has a connotation that is friendly, that is warm and that lasts over time. For me, materials to have life, they need to last over time and should not be discarded. I like the beauty of noble materials. Nowadays, recycling is very popular. When you pick up a noble material at the end, it's a guarantee of quality, but they are also sustainable and add style to any home. For example, if you carry a good leather, or canvas bag, you don't need to carry a synthetic bag that will never age in the end. A leather bag will always have character, a military bag too, a military bag will always give you a result, and it will be nice. When I go to houses where 25 years have gone by, the house is still alive at the end of the day. There might be some details, maybe the screens, that change and

so on but the rest is the same. I think that what is not natural deteriorates in the end and yet, for me, deterioration in a noble material is patina, which is beautiful.

GROËL'S MAGAZINE

Noble materials are definitely your signature, but in terms of style, how would you define yours?

TONI ESPUCH

I think that when it comes to defining what we create is a knowledge of our trajectory, and every time a client arrives, we create a new world. Because in the end the project is destined for the person who is going to live in the house, the premises, the offices, the shop, something more particular. For us it is very important not to lose the property, always trying to make sure that both parties are one. In the end I think you have to listen a lot, get to know, and I think there is a part of psychology as well. I always try to see the client's house, and they tell me: "no! But I don't want you to see my house, because I don't want this type of decoration". Simply by seeing the house you get to know a bit about their tastes, their criteria, what they value,



what they don't value, their free time, how they spend time with their family and loved ones. For me it is very important to get to know the person to be able to develop the project along in the same direction. It is not a project that you want to finish and look pretty and be impractical for the person who is going to live it, it is the full process.

GROËL'S MAGAZINE

What was it like designing the Espuch model? Had you ever designed a door handle before?

TONI ESPUCH

No, it was something new to me. Carlos told me about it once, and I had several ideas. I think that in the future, if I'm allowed to, we'll make another very special one. It was a very nice process, because I was creating something that wasn't available on the market, that I needed for my projects. But at the same time, I wanted to make something that was easy to delete double understand and use for everybody - not something so intricate that you can't really use it. I have achieved a good balance between something contemporary and classic.

Above all, quality is what matters to me, the way Groël has worked on it, the details... It's the most important thing, even though something very simple, it has a lot of soul.

GROËL'S MAGAZINE

Have you encountered any difficulties in creating the handle?

TONI ESPUCH

I think it's really a lot of hard work. Also, thank God I have many years of experience, although there are times when you lack the knowledge, but then it's the practice that gives it to you. I've been able to get to know so much, see so many old houses, see how they were made in the 18th and 17th century... I give a lot of importance to the hardware, you can have a beautiful door and suddenly the hardware spoils everything. Everything you add to a house needs to maintain an existing balance, it has to be part of the home and not draw attention to itself. There has to be an ensemble so that they all have a soul on their own, but they don't stand out. I think I have achieved something very balanced and that just by changing the finishing you can place it in very different places.

GROËL'S MAGAZINE

What was your first impression when you held the handle in your hands for the first time?

TONI ESPUCH

Happiness! Thank you for giving me the confidence to be able to develop something that I am very excited about and that can exist in other places that I have not created. I hope it is a product that people like a lot and that we can make more designs together.



GROËL'S MAGAZINE

What finish would you choose?

TONI ESPUCH

I think the natural brass is the star of the collection, it ages when you use it and the tone changes over time - and I love that. On a natural wooden door, the handle would immediately show a patina that would look very pretty.

Then we have the graphite finish that I love, it looks like gun metal. On camera you might not be able to see it, it looks black but it's not, it's somewhere between grey and chocolate - it has a lot of character. Besides, all the plays and shapes show a lot and I think it's super elegant. You can put it in any house and on any door: whether it's a coloured door, a contemporary door or a classic door, I think it would look great.

The Inox finish is also very nice because it picks up the tones of the elements around it that are reflected on it. If the house is white, the finish will look silver-grey, if there is more wood it will pick a tone closer to an old bronze, and if it is more grey it will accordingly become darker... it picks up a lot of the tones, so I also find it very easy to use.

As for the satin brass, if it was a totally white beach house, I love it. The same goes for the antiqued ones, depending on each space in each home, you can choose between one or another.

GROËL'S MAGAZINE

What is the magic of the Espuch model in non-varnished brass?

TONI ESPUCH

Natural brass is a noble material that lives

with you. You have to have a bit of patience to see the result because several factors such as the pH of each person, how you maintain it and how much use you give to the handle will influence the change of colour. The thing about natural brass is that at first it gives you that feeling of something very new, very shocking and bright, and people are surprised. But as soon as 6 months pass by, it comes to life, it loses this fantasy and starts to take on that patina, which is beautiful, and allows for that famous colour change that gives its personality. There have been clients who have received it and when they compare it to the one in the shop, have said to me "hey, you've sent me the wrong finish!".

It's also true that we are in a Mediterranean area, so maybe this finish in a

house near the sea, for me it's a bit too much... I wouldn't say ostentatious but it's less suitable for the place. It is true that it would take on a very nice tone - I don't mind that and that's in fact what I'm looking for with these noble materials, although, initially you might be a bit surprised. If it's a city flat, the finish will be more stable than in a beach house.

MARÍA TORREGROSSA

Well Toni, thank you very much for your time. It is quite an experience for us to really listen to the person who has designed the model, to know how they feel when creating, their concerns, and what they think of their product or what drives them. At the end of the day, we are the ones who then try to transmit that magic to the clients, and talking to the person who created it always helps us a lot more.

TONI ESPUCH

I think that whenever I work with artists, because we do a bit of gallery work, I try to make sure that the artists get to know the team. When you see a painting sometimes you don't see its soul, right? You may like it more or less, but when you meet the person who has created it each time, it may not be your criteria, you may not like it, but you look at it with different eyes. And you see it and you see that it has a personality, that it has someone behind it, that there is a learning process, a development, a way of expressing, so in the end you are valuing something that even if it's not your criteria... But you are valuing everything that's behind this work!

Thank you very much girls!

CARMINA GOMIS

I only missed Pablito in the interview though...

TONI ESPUCH

I thought they were going to bring him with us!

CARMINA GOMIS

I listened to the sound of his paws walking around and I saw him walking over there, and said well...





The beauty of a hexagon's pure symmetry
turned into a handle collection.

616M. Espuch PULL HANDLE DESIGN

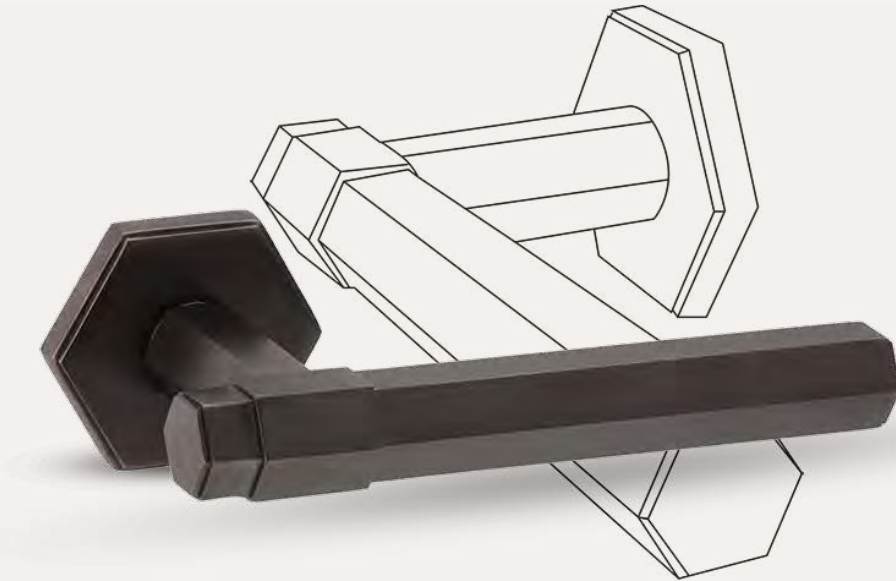

The beautiful symmetry of a hexagon



The balance between something very contemporary and conservative, between something very luminous and noble. **An original model created by Toni Espuch expressing his design attributes into the product:** friendly, warm and long lasting. For very demanding and avant-garde environments but always flexible to adapt to any type of decoration depending on the selected finish.

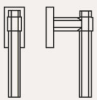

WINDOW HANDLE
616GC ESPUCH

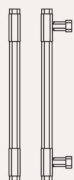

PULL HANDLE
616M ESPUCH

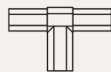

T-BAR CABINET PULL
916T ESPUCH

Nonetheless, for Toni Espuch the star finish is natural brass, a living finish that ages from polished brass to an old brass which has darker and gentle orange tones. **The Espuch design presents a whole collection of accessories:** pull handle, T-Bar cabinet pulls, hexagonal privacy turn & release all available in every finish to complete your project.



616M. Espuch pull handle &
916T Espuch T-Bar cabinet pull.

U_TOPIA

/ju: 'tɒpiə/

An imagined place or state of things in which everything is perfect, usually one that is unrealistic or unattainable. It literally translates as “no place”, coming from the Greek: οὐ (“not”) and τόπος (“place”).

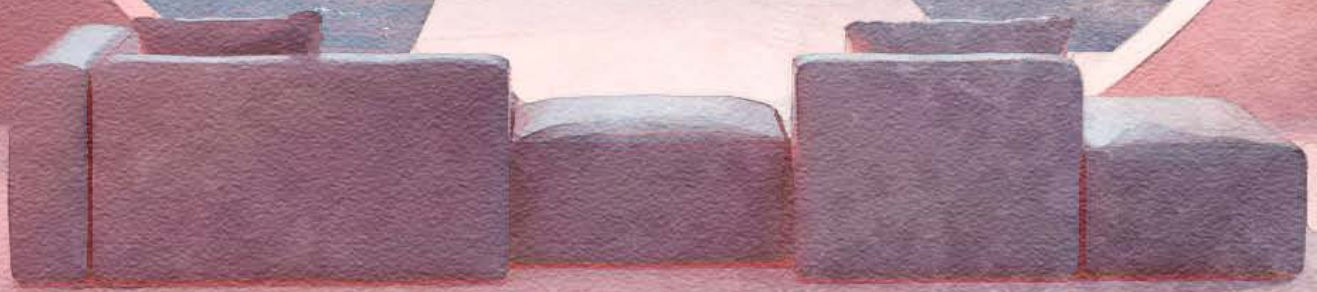
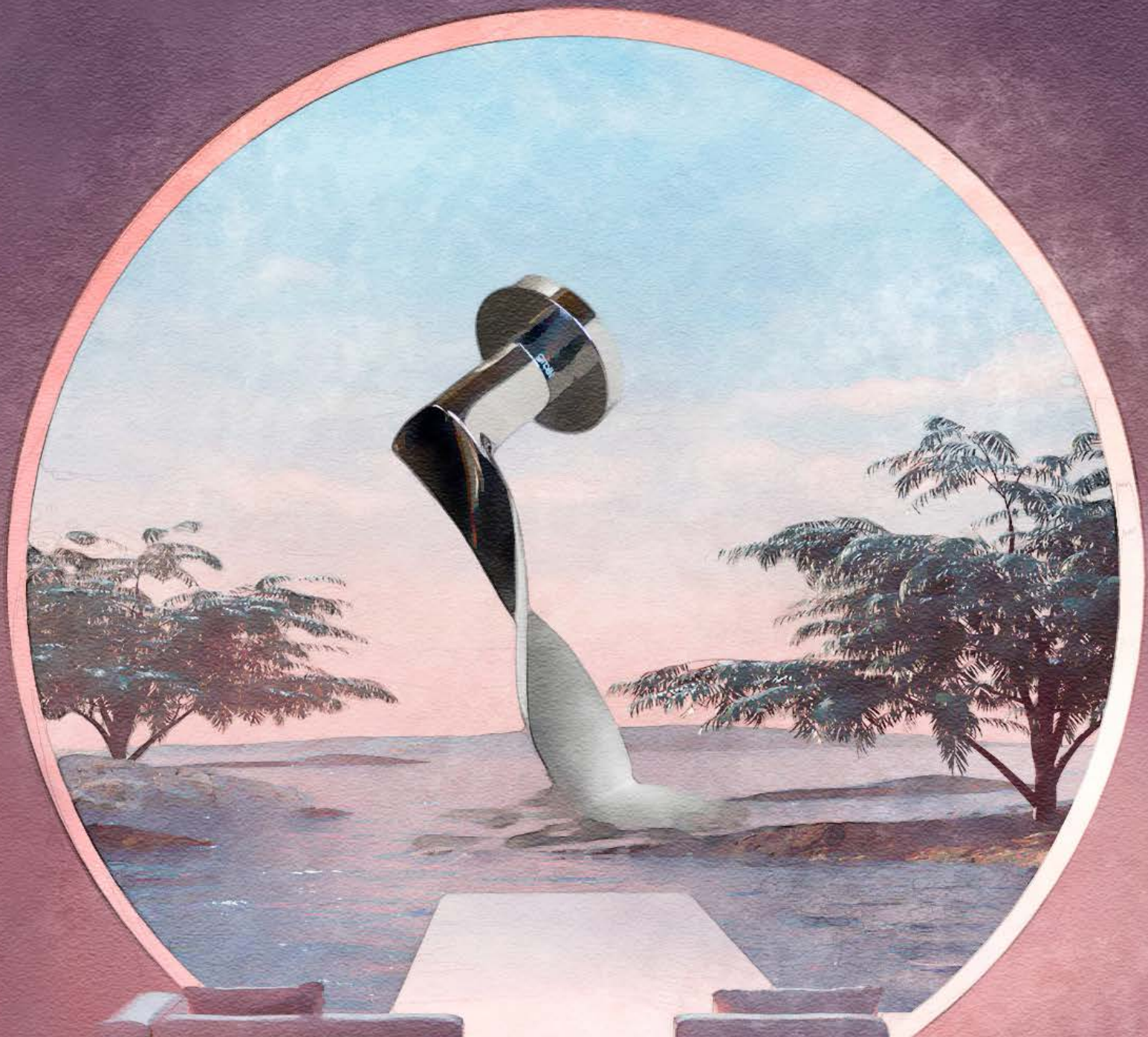

AN EMBODIED CONCEPT

You would wonder where a utopian environment in your daily life could be found. Claiming the realisation or materialisation of utopia in common situations is rather subjective concept that is dishonest to its definition. Paradoxically visualising it, is indeed possible, as long as it exclusively remains an embodied and imaginative concept.

We created the Utopia notion within the world of design to highlight the relevance of inspiration. Because, what's designing really like? Projecting your ideas straight on a piece of paper at the studio would be the easy approach. But here, we want to show the other side of inspiration. That inspiration that invades you when you least expect it, or that inspiration you get from dreams in an unknown world.

PHASE I

Utopia as a short-term provocation. It inverts everything we assume and makes ourselves ask how to create better designs in a flawless and unreal environment where everything is possible.

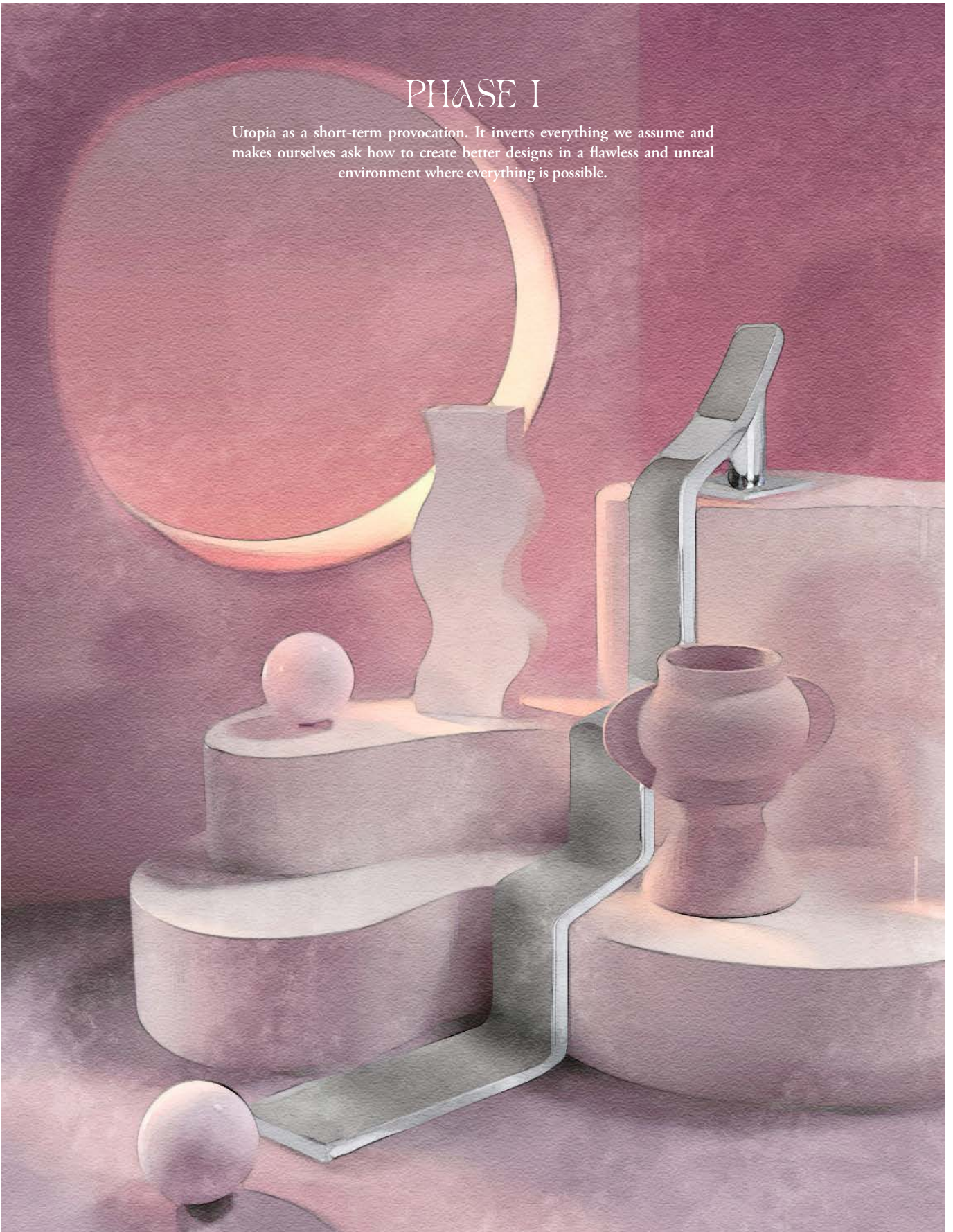

PHASE II

Protopia as a long-term philosophy. It allows us to simply process improvement in our lives and enjoy its results without the need to continuously reach an idealised state.



THERE IS NOTHING LIKE
A DREAM TO GIVE BIRTH
TO THE FUTURE.

UTOPIA TODAY, FLESH AND BLOOD TOMORROW.

VICTOR HUGO

Perhaps the best analogy to view Utopia, is a rainbow. The closer we move to it, the further it moves away. Although we will never reach it, its existence impels us to move forward.

AN EXPERIENCE OF CREATING A PERSONALISED MODEL IN 5 QUICK STEPS.

ALA CARTE

PERSONALISE YOUR MODEL

1. Base

SELECT THE SUPPORT FOR YOUR MODEL.



DOOR



WINDOW



FURNITURE

3. Format

DECIDE THE TYPE OF ROSE FOR YOUR MODEL.



ROUND ROSE

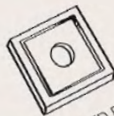

SQUARED ROSE

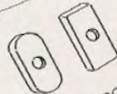

FOR WINDOW



BACKPLATE

2. Style

CHOOSE BASED ON LOCATION.

CONTEMPORARY

ATELIER

RUSTIC

4. Model



520 MANEGA
THE REVOLUTION OF
A TIMELESS CLASSIC.

5. Finishes



CHEF'S SUGGESTIONS



OLD BRASS



SATIN CHROME



POLISHED BRASS



GRAPHITE



POLISHED NICKEL



POLISHED CHROME



MATT WHITE



MATT WHITE



POLISHED CHROME & SATIN CHROME



EBONY & POLISHED BRASS

☆ PowerCoat Titanium powder



ENJOY

— THE CHEF —

We can provide the best solution for you, whether it's supplying our signature products or designing a completely bespoke product with you.

SOKOL(NIKI)
MOSCOW





Sokolniki park

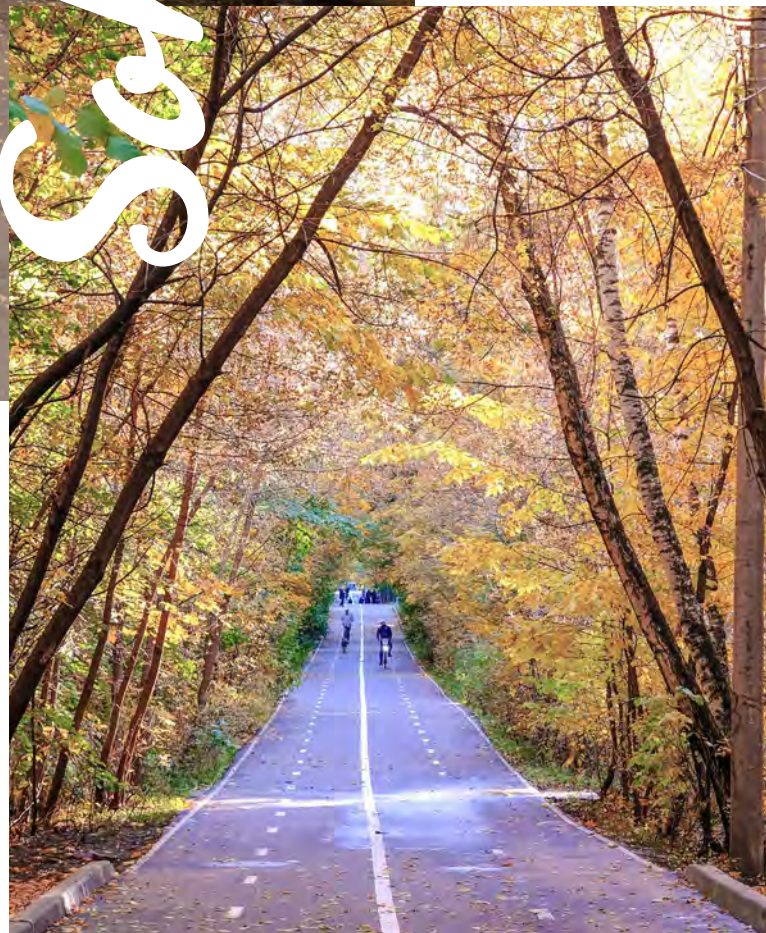

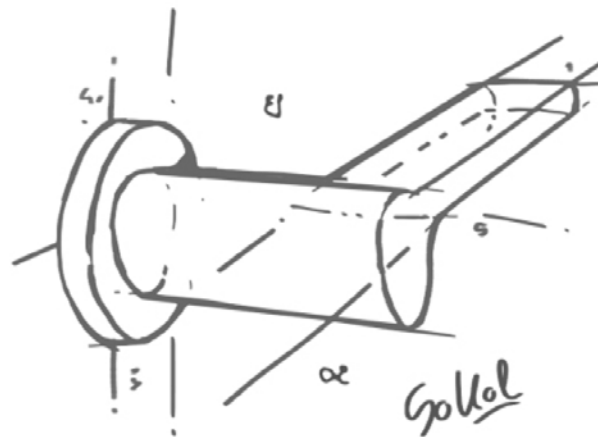

A TRUE STORY - THE EXOGENOUS TRIGGER

As you may have experienced, inspiration sometimes comes when you don't expect it.

Our models are carefully thought out in our studio, but at times the magic comes from somewhere else. On the one hand, inspiration can come as a creative embodied concept - as previously seen in Utopia. But on the other hand, inspiration can set off with your mind in a passive state while just enjoying an ordinary moment. This is what we are dedicating this section to: the exogenous trigger.

The 218 Sokol lever was inspired when walking through the Sokolniki Park in Moscow, where the falcon hunt of the Grand Dukes of Muscovy was formerly conducted. The park gained its name from the Sokolnichya Quarter, the 17th-century home of the sovereign's falconers (sokol [СОКОЛ] is the Russian word for falcon). This place was the trigger of this design. The model was named and designed after those "sokols". It represents a minimalist approach of the aerodynamic silhouette of a falcon's wing, with rounded edges and firmness.

WRITTEN BY **María TORREGROSSA**
PRODUCT DESIGNER **Daniel TORREGROSSA**

GROËL'S PROJECTS

Curve business centre

SAINT-DENIS (PARIS)

CONCEIVED BY
CHARTIER DALIS ARCHITECTES

CARRIED OUT BY
BNP PARIBAS



**THE SOKOL DESIGN
WAS CHOSEN TO
COMPLETE THIS
PROJECT SEEKING
MODERN MINIMALISM
AND ELEGANCE.**

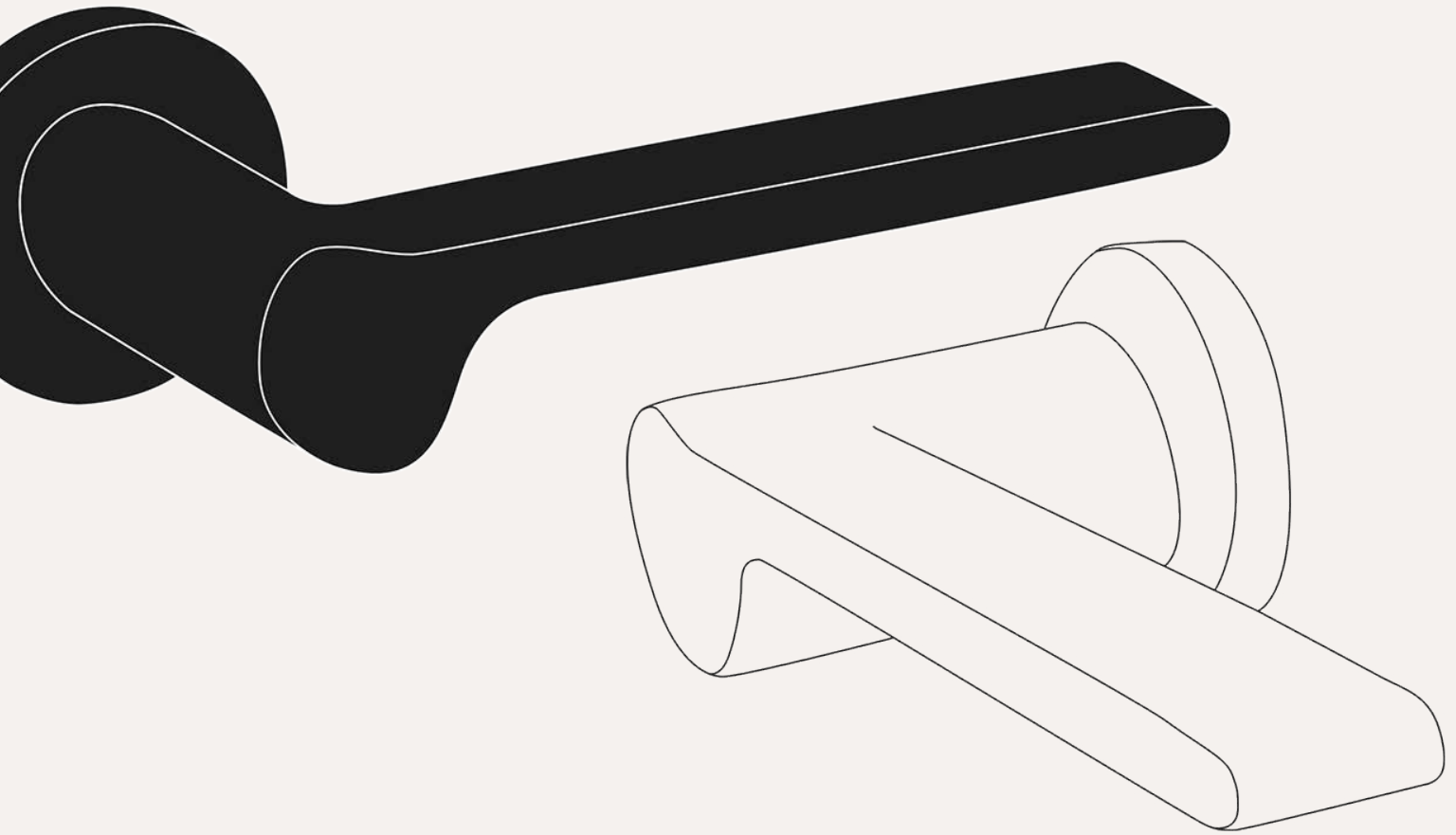

A sky reaching handle

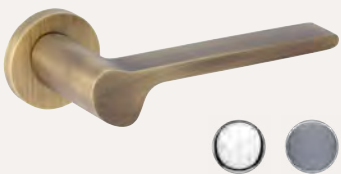

A falcon's wing forged into pure brass. **This Italian made lever handle integrates perfectly with modern and minimalist ambiances.** Nevertheless, depending on its finish it can also be easily integrated in a rustic environment - such as in a more rustic matt bronze finish. This handle design is mostly presented in a round rose which gives an extra aerodynamic look paying tribute to its origin.

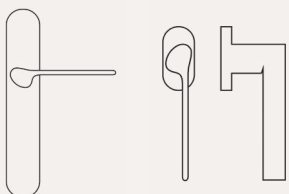

BACKPLATE
218P SOKOL

WINDOW HANDLE
218G SOKOL

A backplate or a window mechanism can also be assembled on this model in the same finish. The combination of our **801M Tecno pull handle** with the Sokol handle in its variety of formats fit together like two peas in a pod. With its symphony of soft curves, the Tecno model achieves a perfect matching with the line of our Sokol design.

La Fabbrica Finishes

DISCOVER THE TECHNICAL PROPERTIES OF OUR FINISHES



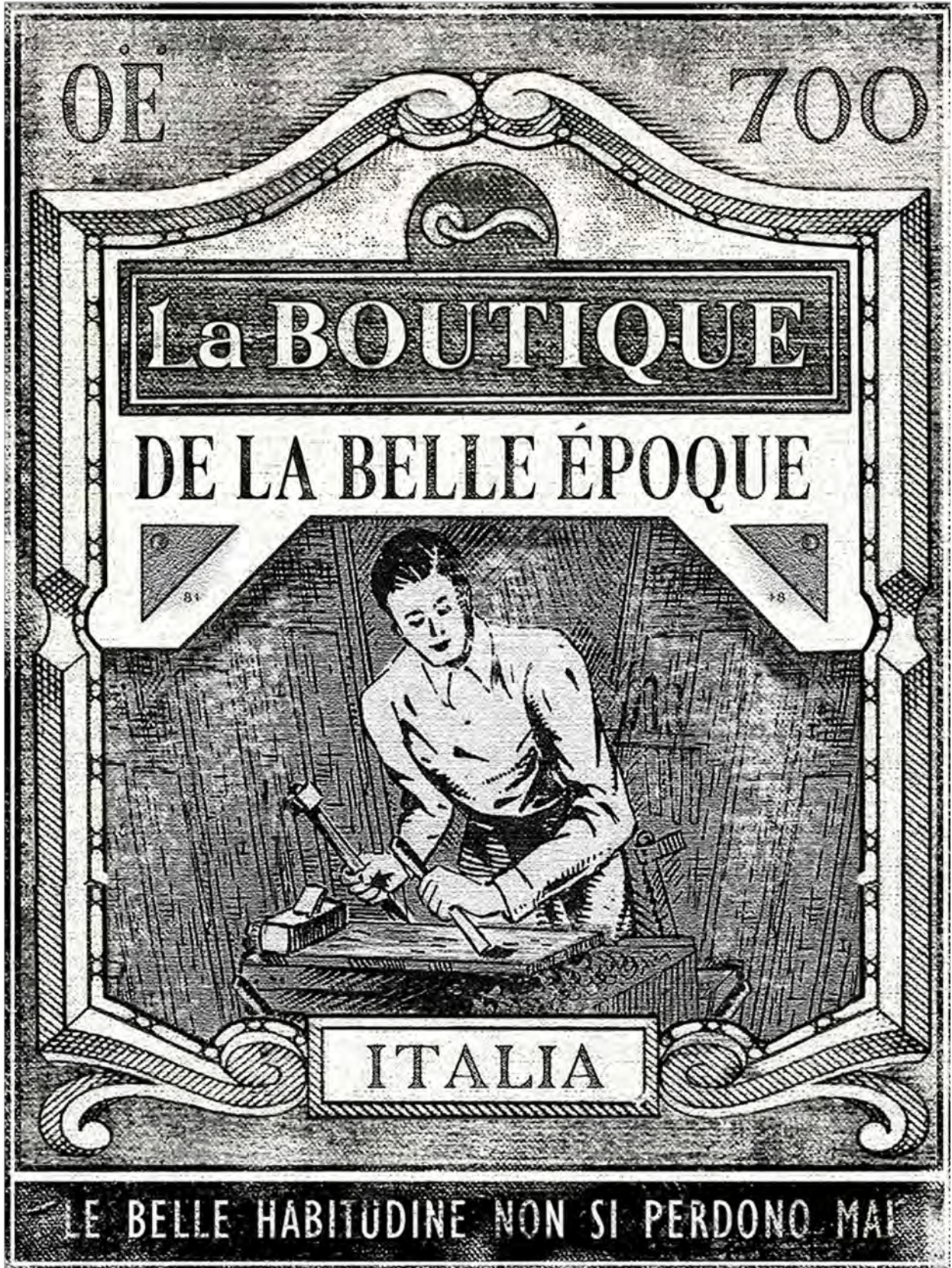

The Encyclopædia Britannica Eleventh Edition, 20th Century.

"OF LATE YEARS CARVING HAS GONE OUT OF FASHION. THE WORK IS NECESSARILY SLOW AND REQUIRES SUBSTANTIAL SKILL, MAKING THE WORKS EXPENSIVE. OTHER AND CHEAPER METHODS OF DECORATION HAVE DRIVEN CARVING FROM ITS FORMER PLACE. MACHINE WORK HAS MUCH TO ANSWER FOR, AND THE ENDEAVOUR TO POPULARISE THE CRAFT BY MEANS OF THE VILLAGE CLASS HAS NOT ALWAYS ACHIEVED ITS OWN END."

This common belief is leading to the gradual disappearance of the foundations of design and the individual artist. At Groël we disproved this statement by preserving wood carving heritage with every single one of our designs.

Being at the top of trends and market's needs does not necessarily mean forgetting about where we come from. We are the first ones to be using the latest technology to create the finest products, nonetheless, we believe in the expertise and essence of tradition as the basis of any artform. The warmth, passion and culture that is endowed with a handcrafted work, can not be transmitted through any automated process. At the end of the day, wood carving is one of the oldest arts of humankind and should therefore be valued as such.

This Italian family of master craftsmen has been collaborating with Groël in the materialisation of design concepts for 25 years. Their beginnings as woodcarvers date back to the start of the 20th century, where their great grandparents initiated this career. Side by side, this family and Groël invest in detail and in the warm qualities of tradition to create the most ergonomic product.

Is there really any better way of giving birth to a door handle design than with your own hands? A door handle is not an ordinary object, it's the harmonious connection between your hands and home.

This phase of idea materialisation is where we give shape to our initial sketch. By visualising the first concept in 3D and manipulating it with this wooden texture, we notice every aspect to be improved. At this point, we usually bring back our prototype to the studio where it gets seen by the whole team, and any feedback is given. For the following process, the modifications on the design are given to the woodcarver and accordingly applied on the prototype. We directly achieve the final version, and if successful, the prototype travels onto the next phase: mould generation.



816. Ipnos lever handle



La boutique de la belle époque

815
DADÁ

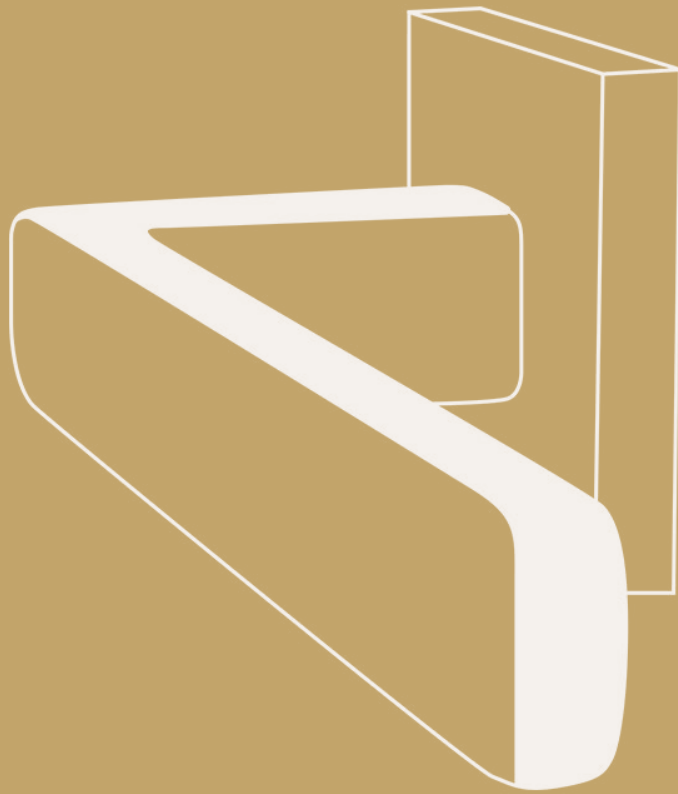

The distended sweetness of geometry



815 DADÁ

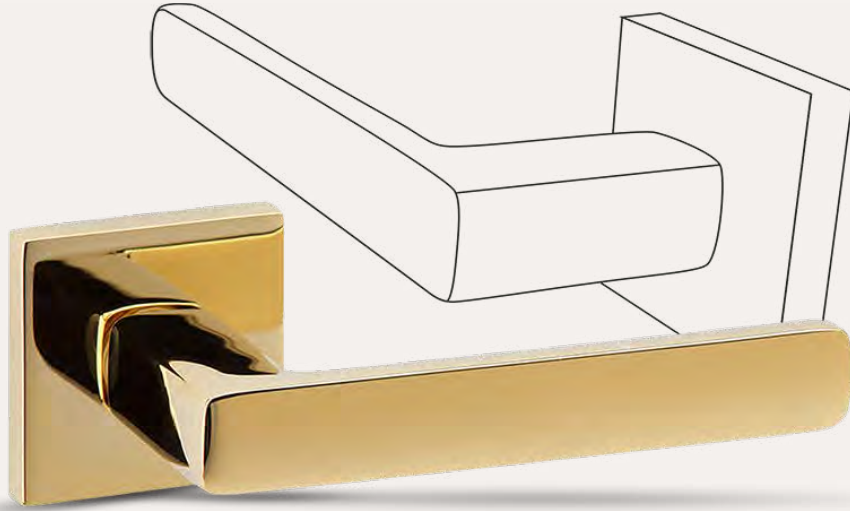

815 Dadá

Investing time in seeing beauty and surrounding yourself with it, will give you life. **This model forged in pure brass is perfect for modern interiors.** Its straight refined lines but slight curved edges perceived at its front, give a unique touch to this minimalist design.

Made in forged pure brass, this lever handle is flexible to any type of decoration due to its wide range of available finishes exclusive to Groël.

First, pick your format: round, square, backplate, or window mechanism. Second, **complete your project in harmony with all the accessories in the same style and finish:** cabinet knobs, escutcheons, privacy turn & release and door stops.

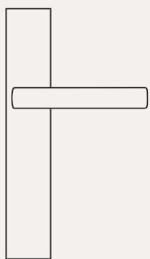

BACKPLATE
815PC DADÁ

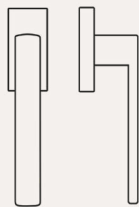

WINDOW HANDLE
815GC DADÁ

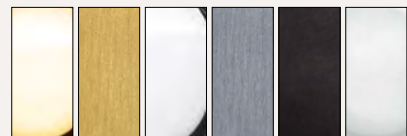

816
IPNOS

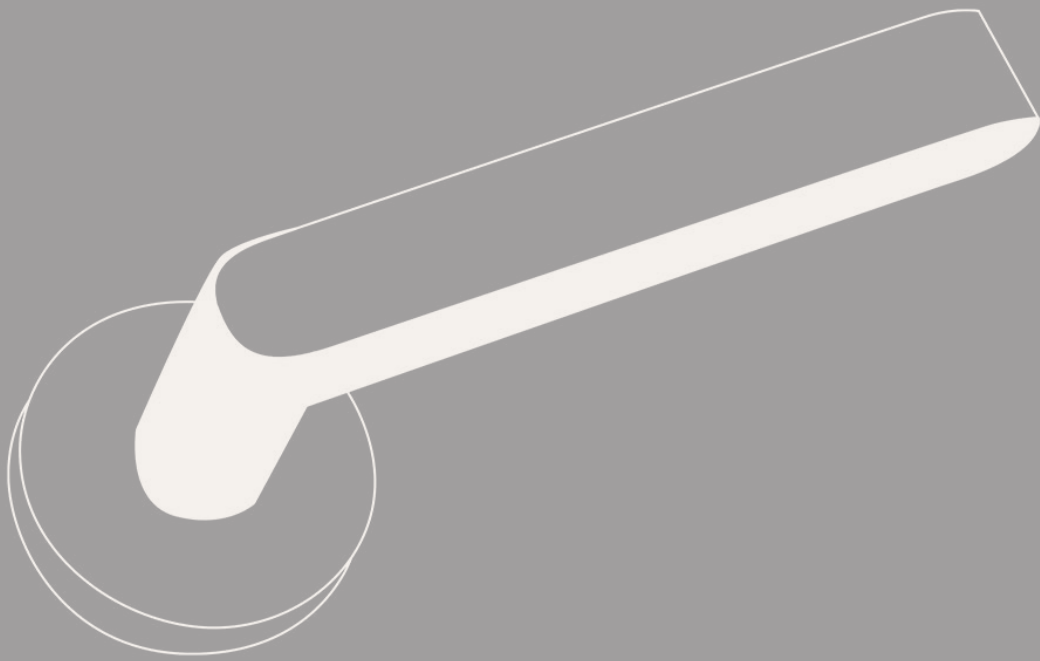

Vigour, vitality and functionality



816 IPNOS



816 Ipnos

Known for having a polished brass surface that looks like a golden ingot. **The Ipnos model made in forged brass will give consistency to your interiors** without disrupting the visual balance. A design like Ipnos is functional beauty in its purest shape.

You can select from our finishes catalogue up to 8 available finishes for this model. Don't forget to pick your preferred format and **complete your project with the rest of accessories in the same finish and style** with cabinet knobs, pull handles, escutcheons, privacy turn & release and door stops.

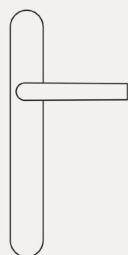

BACKPLATE
816P IPNOS



WINDOW HANDLE
816G IPNOS

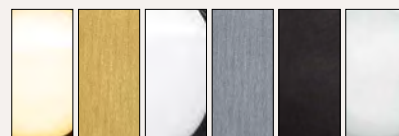



*where ideas
sing*

SAY HELLO TO

New York

THERE'S NOTHING YOU CAN'T DO

The New York lever handle design, with its simple, bright and sleek style, is made of forged brass and is designed for interior and exterior doors in several finishes.

The Empire State style of this handle will inspire you freedom.

PELIZZARI STUDIO®



sono qui
per un altro
motivo

An 18th century palace overlooking the Gulf of Salò.

For this project, in collaboration with Pelizzari Studio, the Shift lever handle is the protagonist of this space.

GESTURES COLLECTION:

Ancestral geometric shapes
describe these movements
in a **FIGURATIVE WAY**,
relating to the mechanism of
the lever handle.

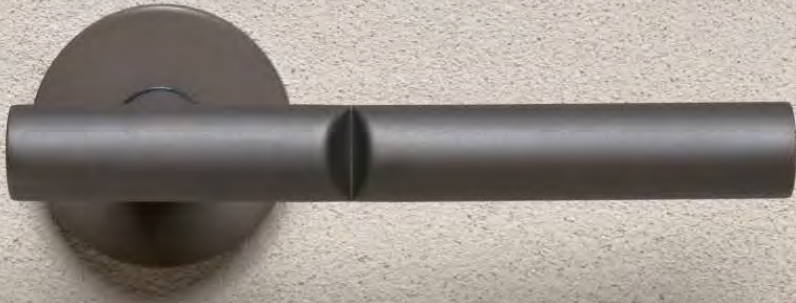

DESIGNED BY **PELIZZARI Studio** / PHOTOGRAPHS **Michael JACKEL**

GESTURES COLLECTION



SNAP represents the act of breaking. A cylinder that stops visually, breaking in the center.
An UNPRECEDENTED and COMFORTABLE lever handle.

GROËL'S COLLABORATIONS



SHIFT represents the gesture of displacement.
An offset and translated cylindrical shape brings back an ORIGINAL and PROVOCATIVE configuration.

GESTURES COLLECTION



PAIR represents the gesture of association.
A circular and a hexagonal element, in contrast, are UNIQUE to create a balanced configuration.

GROËL'S PROJECTS

Biagioni Salò Restaurant

SALÒ (ITALY)

DESIGNED BY
PELIZZARI Studio

PHOTOGRAPHS
Mattia AQUILA







GROËL'S PROJECTS

There is an 18th-century palace on the Gulf of Salò, just a few metres away from the shore of Lake Garda. In this magical place you will find a restaurant where the combination of colours, materials and styles merge to give way to exquisiteness and perfection in a unique and exclusive environment. The **Shift lever handle**, with a cylindrical shape shifted to two levels that gives it an original and provocative personality, fitting perfectly with this beautiful and eclectic space.





For this project, the Pelizzari Studio has chosen the SHIFT lever handle.

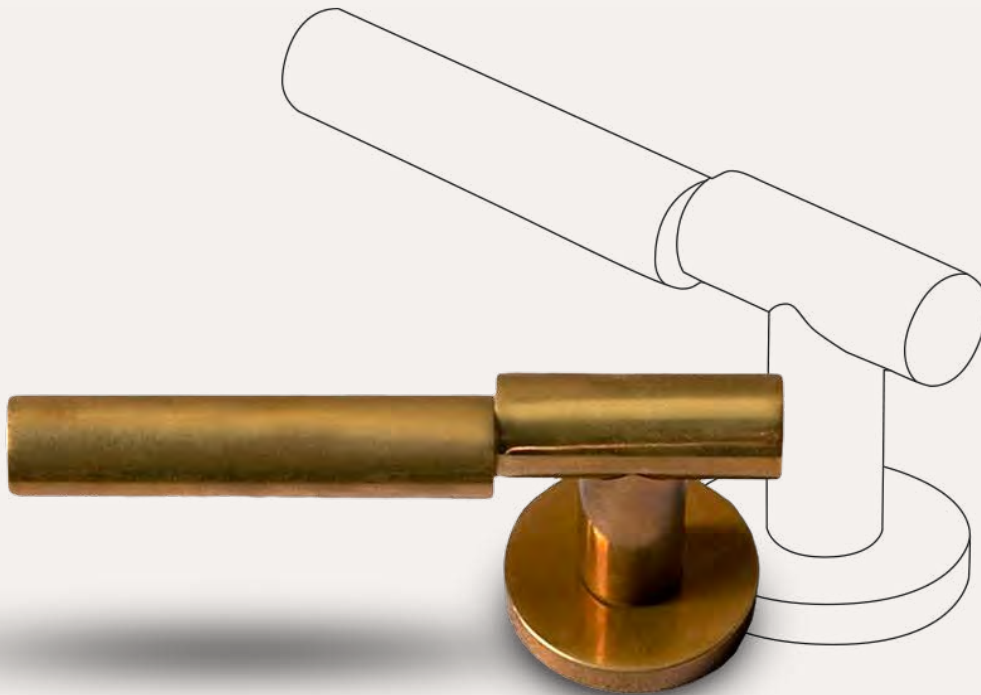

The gesture of displacement



Shift, the most acclaimed of the 3 designs by Pelizzari Studio, represents the gesture of displacement. An offset and translated cylindrical shape becoming an original and provocative configuration. **An aesthetic of deconstructed, broken and interrupted geometries**, for a contemporary and timeless collection made in pure forged brass.

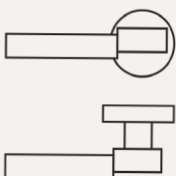

This model created by David Morini was designed to be a passepartout piece, capable to fit in any context, from modern to classic. The characteristic finish of this lever handle is Groël's "old brass", which is a softly bronzed brass giving rise to delicate orange tones.



I
BI
ZA
C
OL
LEC
TIO
N

groël
handmade design

256. IBIZA Cabinet knob





GROËL'S COLLABORATIONS

DAVID MORINI

CEO & Architect of PELIZZARI STUDIO

GROËL'S MAGAZINE

What's Pelizzari Studio?

DAVID MORINI

Pelizzari Studio is an architectural and interior design firm based in Milano and Brescia, Italy. Since 1991 we design villas, apartments, boutique hotels and restaurants. I would chose two strong differentiators to characterize our studio projects: profound know-how and eclecticism. A varied narrative, because "repetitive", in Pelizzari Studio, doesn't exist.

GROËL'S MAGAZINE

What are your values?

DAVID MORINI

Our values are absolute attention to the context in which we design, knowledge of materials and their declination within the project and a tailor-made design that characterizes each of our creations. These elements create unique environments where people can live a better life.

GROËL'S MAGAZINE

What were your inspirations for this model?

DAVID MORINI

The idea came from observing hand gestures during the mundane actions of the daily life. We recognised three main movements and we translated them into our design, giving birth to the Snap, Shift, and Pair models. An aesthetic of deconstructed, broken and interrupted geometries, for a contemporary and timeless collection.

GROËL'S MAGAZINE

What's your approach in design and what's an important thing to consider when designing?

DAVID MORINI

We approach each project by finding a strong conceptual idea. Any decision we take on the design revolves around this concept.

GROËL'S MAGAZINE

Is your first sketch/testing close to the end result?

DAVID MORINI

For this project we had a clear idea in our mind and we were able to translate it, without compromises, into the finished product.

GROËL'S MAGAZINE

What challenges did you face when designing the lever handle and what did you learn from this collaboration?

DAVID MORINI

We didn't face any big challenges since, during the entire development process, we had full comprehension from Groël, who are the professionals in this area at the end of the day. Thanks to this collaboration we learnt how much attention Groël dedicates to the design and production of handles. We learnt that each piece is carefully produced firstly by hand with extreme expertise and later with the most advanced technology for quality standard purposes.

GROËL'S MAGAZINE

How would you describe the end product?

DAVID MORINI

The end products are timeless pieces suitable for every context. An interesting and modern uptake. **Shift**, the most acclaimed, representing the gesture of displacement. An offset and translated cylindrical shape becoming an original and provocative configuration. The **Snap** model represents the act of breaking. It's a cylinder that is visually stopped by breaking right in the middle. A completely unprecedented and comfortable handle. Then the **Pair** design represents the gesture of association. It's the combination of a circular and a hexagonal element, which in contrast, are unique to create a balanced configuration.

GROËL'S MAGAZINE

In your opinion, what is the best finish for the lever handle and what interiors would it suit?

DAVID MORINI

Our lever handles are designed to be passepartout pieces, capable to fit in any context, from the modern to the classic ones.

GROËL'S MAGAZINE

What do you expect from this lever handle commercially?

DAVID MORINI

Having such a versatile design and finish, combined with very high quality, we expect a positive reaction from the market.

GROËL'S MAGAZINE

Does this lever handle fit within Pelizzari Studio projects/style?

DAVID MORINI

The handles' design fits perfectly with the aesthetic of Pelizzari Studio. We used these models in several projects such as: Biagioni Salò Restaurant (Salò) and Classico Ristorante (Brescia).

“What is our motto?:
beauty is in the **balance of space**”



GROËL'S PROJECTS

Rastrello Boutique Hotel

PANICALE (ITALY)



DESIGNED BY
PELIZZARI Studio

PHOTOGRAPHS
Mattia AQUILA



For this project, the Pelizzari Studio has chosen the PALLINE handle.

GROËL'S PROJECTS

In a fourteenth-century nobility palace located in Panicale, Italy, Pelizzari Studio intervened with a restoration of architectural conservation and a seismic improvement thanks to the inclusion of contemporary technological systems and interior design. This seven-room boutique hotel and an independent apartment have been decorated in detail, as well as the restaurant that is located on the same grounds, giving different personalities to each environment. To this end, the Palline lever handle was chosen, with a design that does not deny tradition and that rejuvenates the most classic environments.



533 PALLINE

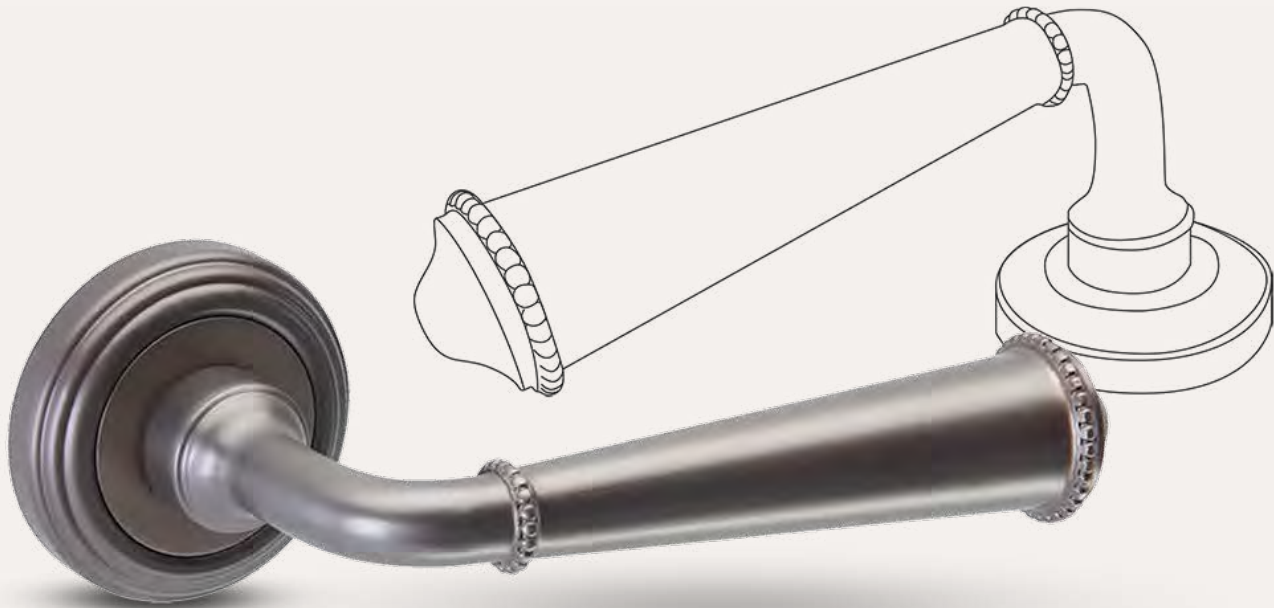

Historical glimpses, alluring charms



A very thorough design elaborated in pure forged brass. **This handle was named after the meticulous and radiant details on its grip, called “palline” in Italian.** This model belongs to Groël’s Atelier collection which seeks modernised and elegant classic designs. The Atelier rose is specially staggered to add personality and character.

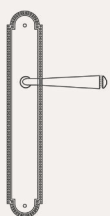

BACKPLATE
533P3 PALLINE

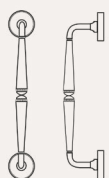

PULL HANDLE
533M PALLINE



WINDOW HANDLE
533G PALLINE

Popular finishes are polished brass or polished nickel, however this door handle includes an exclusive brown edition which fits into every type of interiors. **This model also presents a pull handle in the same collection, as well as other Atelier accessories such as escutcheons and privacy turn and release.**

*a
groël
creative
experience*

We can give you solutions for any type of accessory for your project, in any matching finish. Groël wants to give you the full experience the brand has to offer: not just products but also solutions for spaces and relationships. While versatility is one of Groël's best attributes, allowing us to insert the brand any given space and time, our capacity to adapt capitalises on the power of all our outlets as well as finding new touch points. We can give you solutions for any type of accessory for your project, in any matching finish. This is how we manage an expansion in new and cross-sector environments.

**LIFE IS AS
INDIVIDUAL
AS YOU ARE.**



More than a cabinet pull.

956A. IBIZA CABINET PULL HANDLE IN POWERCOAT GRAPHITE FINISH.





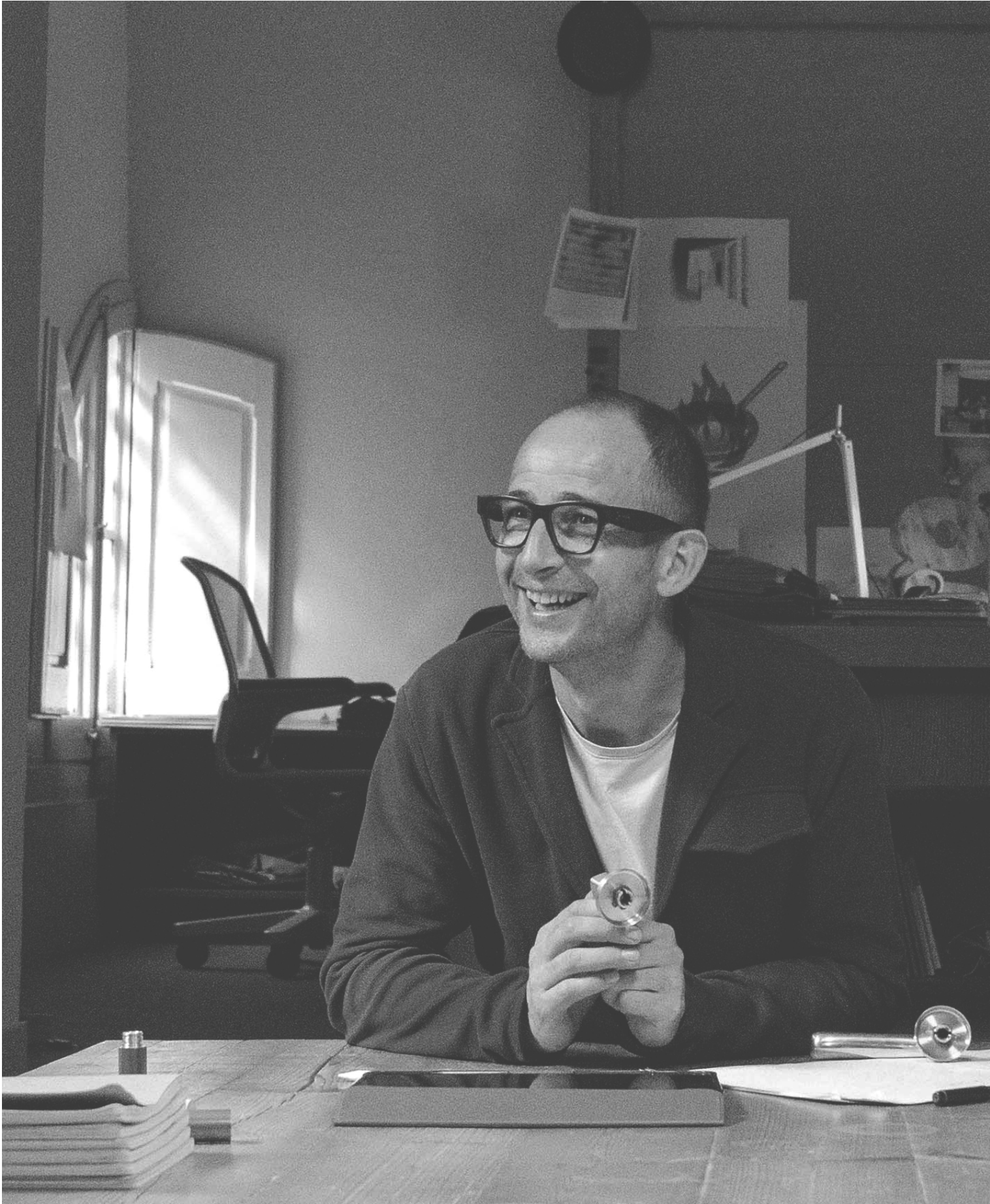

Groël x

lagranja





GERARD SANMARTÍ

I'm Gerard Sanmartí, Co-founder & Partner of Lagranja Design. We are a multidisciplinary design firm in Barcelona working with 20 designers for 20 years now. We blend creativity, production skills, business sense and visual marketing into effective design projects. We basically are between interior design and product design.

GROËL'S MAGAZINE

How was the experience of designing a lever handle?

GERARD SANMARTÍ

We have always loved lever handles as they are an essential element in our interior design projects. It's a very detailed and unique product that is sometimes invisible for many people, but for a designer it's a very delicate piece - like jewelry. Designing a lever handle was a completely new experience for us. We have designed so many things during these past 20 years in the industry, from chairs to lighting, but never a lever. Therefore, this experience has been very enriching and we have learnt all the features to be considered when designing a lever handle. We had to pay attention to so many aspects: the curves, the polishes, and the finishes in order to make the proportion to be ergonomic.



GROËL'S MAGAZINE

What's an important thing to consider when designing?

GERARD SANMARTÍ

It's crucial to firstly take into consideration that the creation must be functional but beautiful. Functionality is not always beautiful, but what's beautiful is always functional. That is why we firmly believe that beauty has the power to enhance anyone's lifestyle. The second most important aspect is that it has to merge in every type of project and style: from modern private housing, to classic hotels, or even nightclubs. This is what we were trying to do here, something that fits many different contexts.

GROËL'S MAGAZINE

What challenges did you face when designing the lever handle, and what did you learn from this collaboration?

GERARD SANMARTÍ

In the market there are many levers, so introducing one with new ideas is difficult. When starting this project so new and different to us, we had the feeling of "everything has been invented, how can I make something new?". For example, a usual product design for us is a chair; there are many of them, and every single one is different. On the one hand, a chair is composed by several structures,





such as the legs, back support, seat, arm support and with a greater surface than a handle. This means that more variables can be modified and combined to give rise to a new product. A handle on the other hand, is distributed in a much smaller space, which means having to pay attention to each millimeter, because each millimeter matters even more – which isn't easy. A handle must indeed be treated like a jewel.

GROËL'S MAGAZINE

Is your first sketch/prototype close to the end result?

GERARD SANMARTÍ

Not really. At the beginning, the lever handle was shorter and thicker, and the grip had more depth. We learnt the importance of taking special care of the transition from the sketches, to the computerised design, to the 3D printed prototype to the final result. The key element is being conscious about the material, which is brass and is shiny, and results in a completely different appearance. The wooden prototype and the 3D model compared to this polished brass or satin brass model, don't have anything to do with each other. It's like a completely different lever handle due to metal's properties and presence. When designing a lever handle, getting the right proportions is harder than expected. Groël masters the proportions of the handle design, the transition between materials, and the market much better than us. This is why they helped us out through the design process, to pull off the design in the best possible way. The aim of collaborations at the end is just having designers sharing their experience and ideas to create the best possible product.

GROËL'S MAGAZINE

How would you describe the end product?

GERARD SANMARTÍ

Super well-done! A very high-quality material and finish. Absolutely surprising. This lever handle combines both modern and classic style. From the front, it has a flat surface with a more classic appearance. However, the back side is fully ergonomic, giving a modern touch to this model. This has been a whole new experience for me and the rest of the team because we have never done anything similar to this. We were all excited to see the end result and now we are all just in love with it.



GROËL'S MAGAZINE

What, in your opinion, is the lever handle's best finish? and what interior would it fit into?

GERARD SANMARTÍ

In all interiors, modern or classic based on the selected finish. For the finishes, I'd personally say I prefer matt over shine - which is probably more classic. However, I think both would fit pretty well, it would only depend on the type of environment you're trying to create.

GROËL'S MAGAZINE

Commercially, what are your expectations?

GERARD SANMARTÍ

I will retire with this model. Absolutely.

GROËL'S MAGAZINE

Does this lever handle fit within Lagranja's projects/style or is it very diverse?

GERARD SANMARTÍ

It's difficult for us to describe ourselves. We are a big group but we work very well because we have been together for a long time now, so we end up working the same way. Nonetheless, every project is different and we also try to do every project differently from the previous. We try not to repeat ourselves but at the end, all our projects have Lagranja's essence of design, and we are proud of that.

GROËL'S MAGAZINE

Do you have a name in mind for this model?

GERARD SANMARTÍ

Honestly, my partner Gabrielle is more clever than me in this aspect. To be honest I don't really know. María has probably got something to say.

MARÍA RUIZ (HEAD OF PRODUCT DESIGN & ART DIRECTOR)

What do you think about Bimba?

GERARD SANMARTÍ

Bimba? Perfect. Fantástico.



GROËL'S COLLABORATIONS

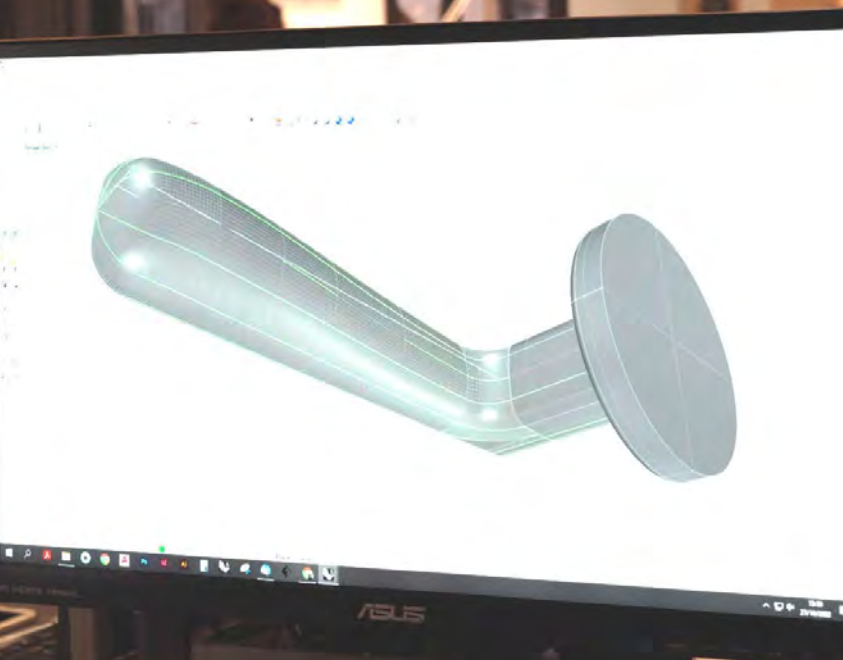

BIMBA

Every good design project starts with a great story.



Groët x
lagranja



246 BIMBA

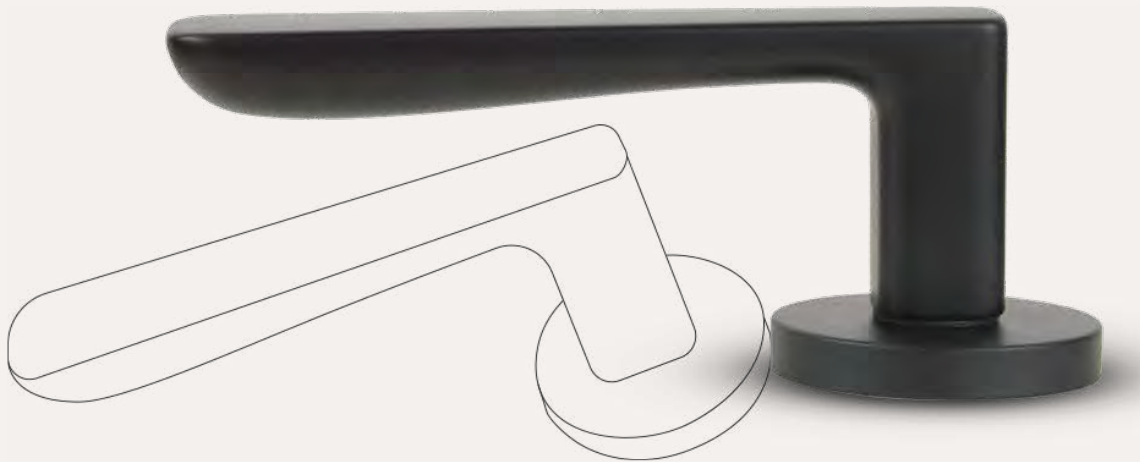

246 Bimba

A very delicate piece, a jewel

The new model launched in collaboration with **Lagranja Design**. A lever handle combining a modern and a classic style. From the front, a flat surface with a more classic appearance but from the back side it is fully ergonomic, giving a modern touch to this model. **Bimba merges in every type of project and style:** from modern private housing, to classic hotels, or even nightclubs.

The designer Gerard Sanmartí prefers matt over shiny finishes, such as satin brass or matt black, but claims “it would only depend on the type of environment you’re trying to create”. **Stay tuned for all the upcoming original accessories in this collaboration to complete your project.**

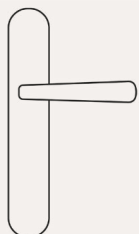

BACKPLATE
246P BIMBA

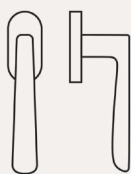

WINDOW HANDLE
246G BIMBA



groël
handle design



MANEGA

THE REVOLUTION OF A TIMELESS CLASSIC



RUSTIC MATERIALS

Warm and cosy atmospheres with a rustic character have always had a certain charm, especially in the Mediterranean. Wooden interiors with a soft warm lighting, rustic and robust furniture always give a sense of peace and well-being.

Decorating these spaces with accessories in brown tonalities, antique silver, bronze or antique brass is always a success. It brings a touch of originality to any rustic space.

At Groël, the variety of existing styles and the desire to adapt to any environment led to the creation of rustic models in which, with brass as the primary element, the finishes and other materials, merge to create the perfect rustic lever handles.



809. KILTO
Brown finish



108. BEL.LA
Fumé & Craquéé finish

RUDE BUT CUTE

The rustic lever handles whose only material is brass, as is the case of the Kilto model, stand out for their design and originality, fitting perfectly in any environment depending on the finish applied to them. Within the Kilto collection we find the rose, the escutcheon, the keyhole and the pullhandle, which were conceived to complement the lever handle and thus provide any room with great harmony. Although brown is the most commonly selected finish, antique silver, satin or polished bronze and antique brass are equally adaptable to these environments. As a whole, they can be perfectly combined with other materials such as porcelain or ebony wood.



808. DEV
Brown & White porcelain finish

The use of these materials, particularly porcelain, adds a delicate touch to classic and rustic designs, as is the case with Dev or Bel.la lever handle designs. Moreover, the porcelain used is not limited to white but, in order to blend in with the environment, Groël uses ivory-toned porcelain in both models. In the case of the Bel.la lever handle and its matching doorknob, the variety of porcelain is even more extensive and can go from a uniform beige to blue craquéé.

WRITTEN BY **Vanessa RUIZ**
PRODUCT DESIGNER
Daniel TORREGROSSA

809 KILTO

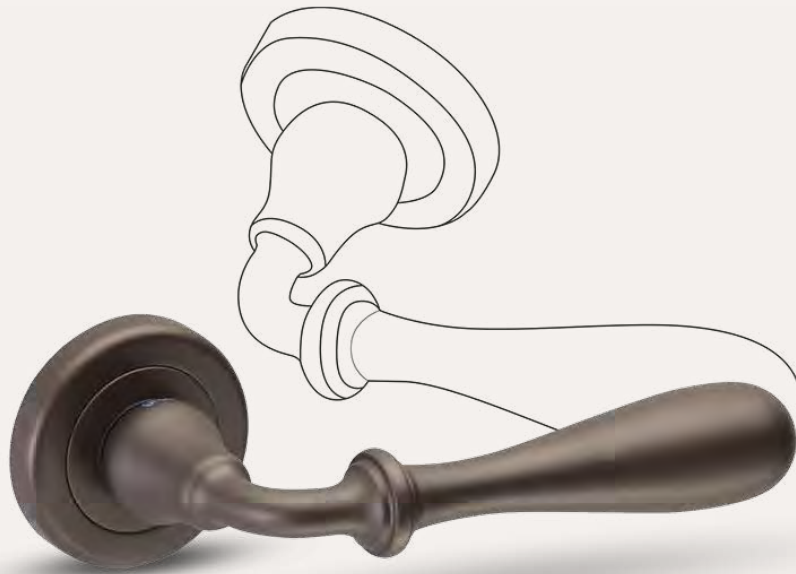

809 KILTO

Transcending time and fashion

A perfect fit for classic and modern environments. Standing out for providing that traditional detail that completes the conventional design. Within **the KILTO collection we find the rose, the backplate, the escutcheon, the keyhole and the pull handle**, which were conceived to complement the lever handle and thus provide any room with great harmony.

This design made in pure brass is found in special rustic finishes such as: satin bronze, effetto ferro, antique brass and brown.

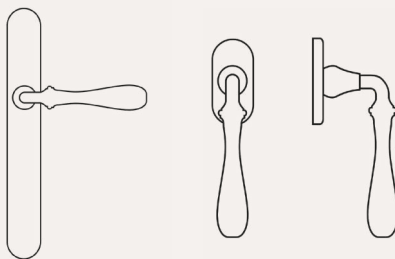

BACKPLATE
809P KILTO

WINDOW HANDLE
809G KILTO

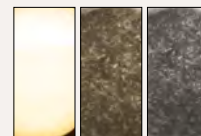

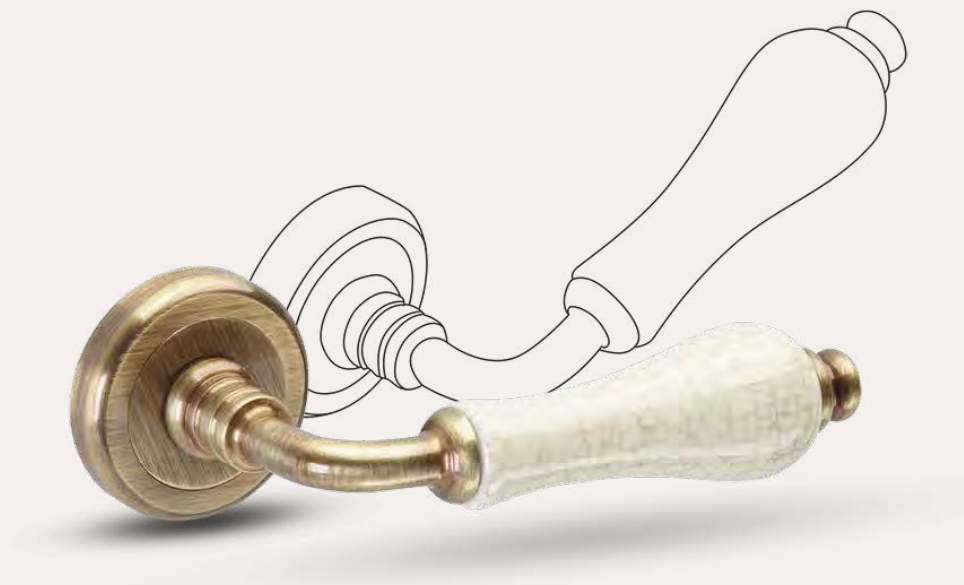

108 Bel.la

A mediterranean true classic

This lever perfectly merges in any type of rustic ambiance due to all the different combinations between the brass base and the porcelain. The Bel.la design uses a variety of porcelain styles from white or ivory-toned porcelain to give a warmer touch to blue "craquelé". **This lever handle presents an exclusive "craquelé" technique**, which consists of imitating the cracks that appear in works of art due to the passage of time, trying to give the same appearance to the handle.

The base of the rose and neck made in brass can be found in satin or polished bronze, polished brass, antique brass or "effetto ferro". **Complete your collection with the Bel.la pull handle and the rest of rustic accessories:** escutcheons, privacy turn and release, sliding door kits and in all the different available formats.

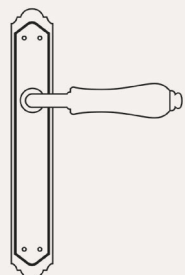

BACKPLATE
108PM BEL.LA

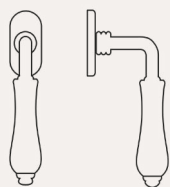

WINDOW HANDLE
108G BEL.LA

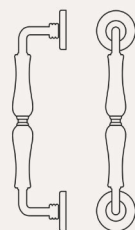

PULL HANDLE
110M BEL.LA

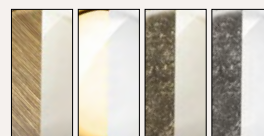

808
DEV



808 Dev

A charming pearl effect

One of Groël's original models. A design with a powerful presence and a traditional design, is made in forged brass and a porcelain grip creating a charming pearl effect on a round rose. **This model fits perfectly in rustic and warm spaces** and the neck made in brass can be personalised in a polished brass finish or brown finish.

Complete your collection with the following rustic items in the same finish: **Kilto pull handle, escutcheons, privacy turn and release, sliding door kits.** You can also change Dev's format into a backplate or for windows.

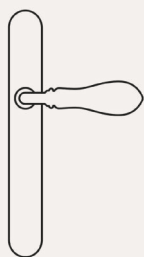

BACKPLATE
808P DEV

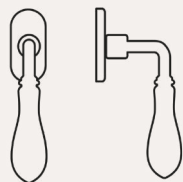

WINDOW HANDLE
808G DEV

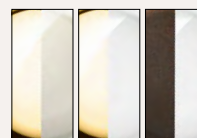

Cabinet hardware with
exclusive designs.





Ma chérie

Je t'aime,
ma chérie.



The minimum expression of a perfect tandem.
CHÉRIE COLLECTION.

590 CHÉRIE



Je t'aime.



A sweet hearted design made with the highest delicacy and precision. **This design is specially conceived in dense ebony wood and paired up with pure brass on an exclusive rose.** Nickel finishes complementing the ebony wood have been finely selected to provide harmony in your projects.

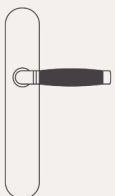

BACKPLATE
590P CHÉRIE

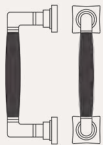

PULL HANDLE
590M CHÉRIE

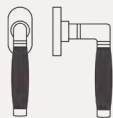

WINDOW HANDLE
590G CHÉRIE

We also propose unlacquered brass to promote the beauty of natural and noble materials. Together, they offer a very chic and bold touch, perfect to stand out in any room seeking for an avant-garde style. **This model has been granted a whole collection including T-bar cabinet knob, cabinet pulls and all the accessories.**

Chérie Collection

Far from the classic aesthetics of rustic lever handles, the Chérie Collection has been designed to provide a new and more advanced rustic style or the most demanding and avant-garde interiors. A design combining pure brass with dense ebony wood, a tropical wood considered one of the most beautiful and unique because of its dark colour, close to black. With the birth of the Chérie lever handle, an exclusive rose is created and subsequently, a matching T-bar cabinet knob, cabinet pulls and more accessories.



TAILORING

A GROËL CREATIVE EXPERIENCE FOR PROJECTS

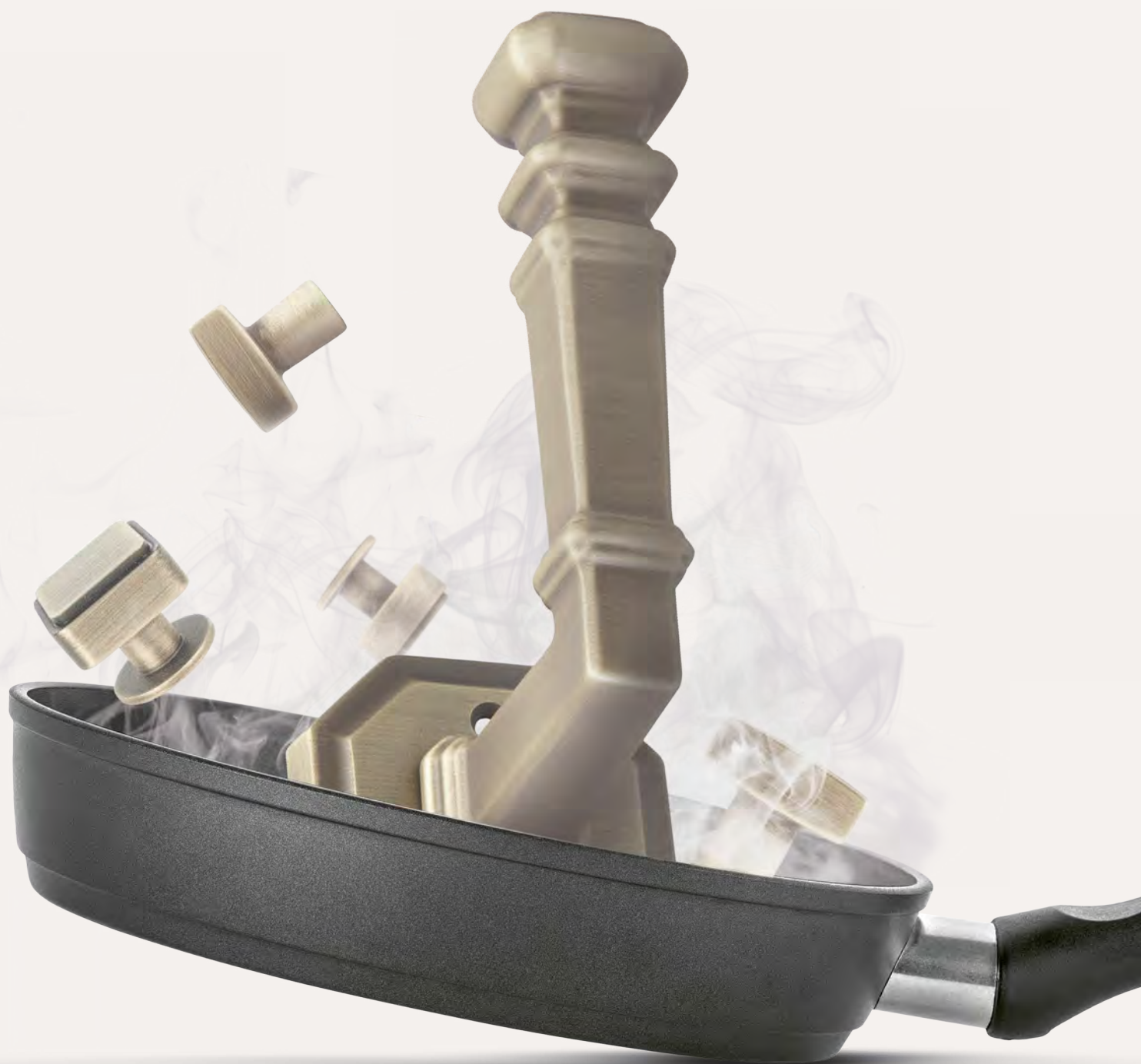



BENVENUTI

CREATE HARMONY IN YOUR PROJECT, EVERY ACCESSORY
IN THE SAME PERSONALISED FINISH.



We are not limited to manufacturing handles and their accessories, instead we can create any piece you might need to complete your interiors.

Groël wants to give you the full experience the brand has to offer: not just products but also solutions for spaces and relationships. We are not limited to manufacturing lever handles and their accessories, instead we can create any might need to complete your interiors. While versatility is one of Groël's best attributes, allowing us to insert the brand any given space and time, our capacity to adapt capitalises on the power of all our outlets as well as finding new touch points. We can give you solutions for any type of accessory for your project, in any matching finish. This is how we manage an expansion in new and cross-sector environments.



01

UNDERSTANDING YOUR NEEDS

To capture your requirements in the best possible way we involve our specialists at the very beginning. We will first assess whether you need a customised supply of our signature models or a completely personalised design. In this way we manage to scope out and understand in depth the initial concept, design, finishes, deadlines and budget. When this phase is completed, sketches, technical sheets, and samples will be provided.

02

PROJECT MEETINGS

We fully believe in the importance of professional connection achieved by in-person contact. Where possible, we arrange visits to the studio/site/offices and online meetings with the team to ensure everything runs smoothly. We also provide trainings to explain all about the specific solution exclusively for your project, including an overview of our manufacturing, our raw materials and finishes.

03

OUR COMMITMENT

We are highly experienced in projects, hence we know the challenges we might be facing as well as what challenges you can face while managing multiple suppliers. This is why we want to be an extension of your own team, and make it easy for you to collaborate with us. We are ready to assist you to the best of our knowledge and expertise throughout the stages of the project. You will get a full professional advising and follow up service.

You're the author
of your story.





217M. Sketch PULL HANDLE DESIGN

The details are not just
details, they make the design.



I
BI
ZA
C
OL
LEC
TIO
N

Feel the texture



All about **IBIZA**

The essence of the white island imbues more and more homes and spaces in the Mediterranean every day. A fresh and clean air that recalls the smell of the sea; a luminosity in the surroundings that provokes peace and serenity. Despite the simplicity and sobriety of the Ibizan style, as the essence is in the details, the **Ibiza Collection** makes the difference and stands out for its great character in any of its finishes, the most requested being our Powercoat graphite.



The birth of the Ibiza lever handle in 2018 went hand in hand with the construction project of a complex made up of luxury villas located on the white island, hence its name. We were given the task of creating an original, unique, sensory and characterful handle, in tune with the essence of the island, and so we did. These villas built with top quality Ibizan materials, surrounded by gardens, swimming pools and nature, bathed by the Mediterranean Sea, were conceived so that light, calm and freshness were dominant and it was the complements and accessories that provided a personal touch.

N CALMA HOMES

For this project, a lever handle was conceived and created with a special machining, a combination of "zingrinato" on grip with a smooth surface reaching its neck landing on a round rose. To complement this lever handle, smooth keyholes and escutcheons were added, where the originality lies within the zingrinato escutcheon button, offering a contrast of textures that brings detail and modernity to the overall product.



256
IBIZA

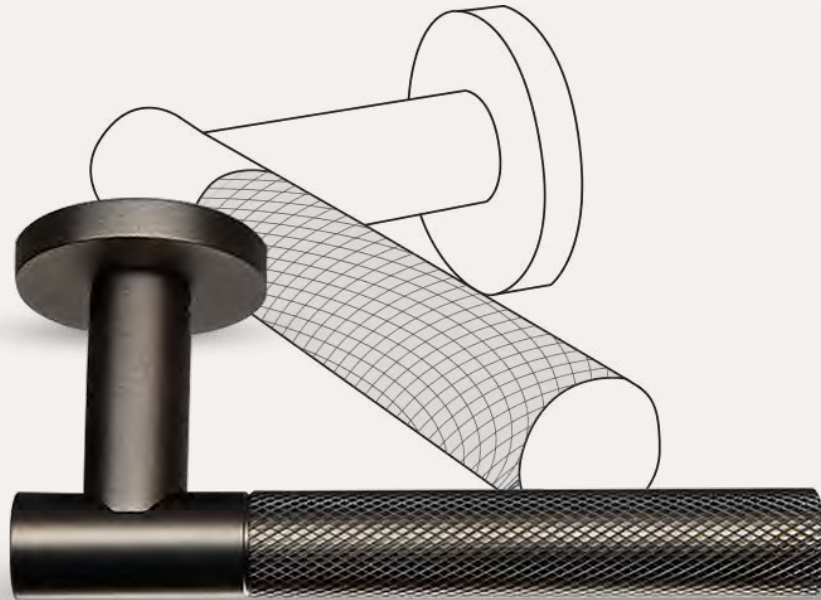
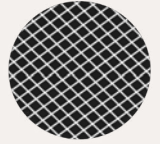

Close your eyes and feel the texture



An original, unique, sensory and characterful handle, in tune with the essence of the white island. Despite the simplicity and sobriety of the Ibizan style, as the key is in the details, **the Ibiza Collection makes the difference and stands out for its great character** in any of its finishes, the most requested being our Powercoat graphite.

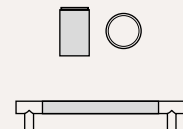
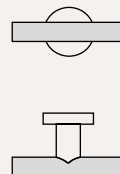
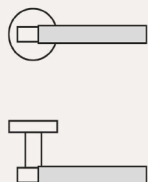

GROËL'S COLLECTION

In addition, with the aim of increasing the harmony of the interiors, the accessories that make up the **Ibiza Collection** were created. This collection presents pull handles in two sizes, one 70 centimeters and the other 40 centimeters, with the same design as the lever handle, so that they can be installed both on doors and wardrobes.

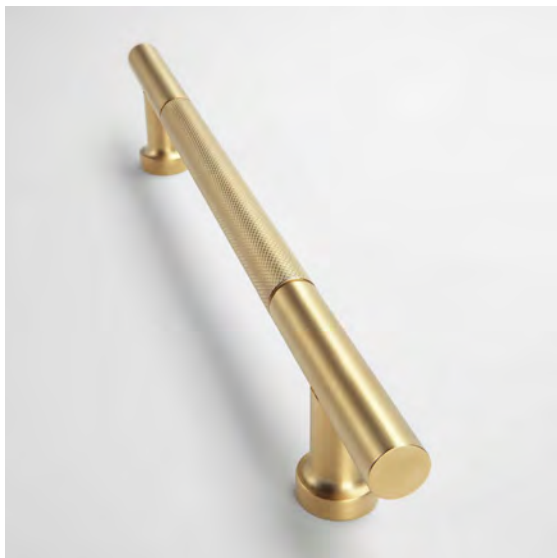

Cylindrical cabinet knobs were also created with *zingrinato* machining for drawers and furniture as well as small cabinet pull handles for drawers similar to the bigger ones. Finally, a T-shaped handle version was added to the collection, ideal either for windows or for doors, breaking from the classic lever handle to a more avant-garde design. This model with pull handle function for sliding and hinged doors, as well as for furniture, is presented as the novelty of the collection for the year 2023.

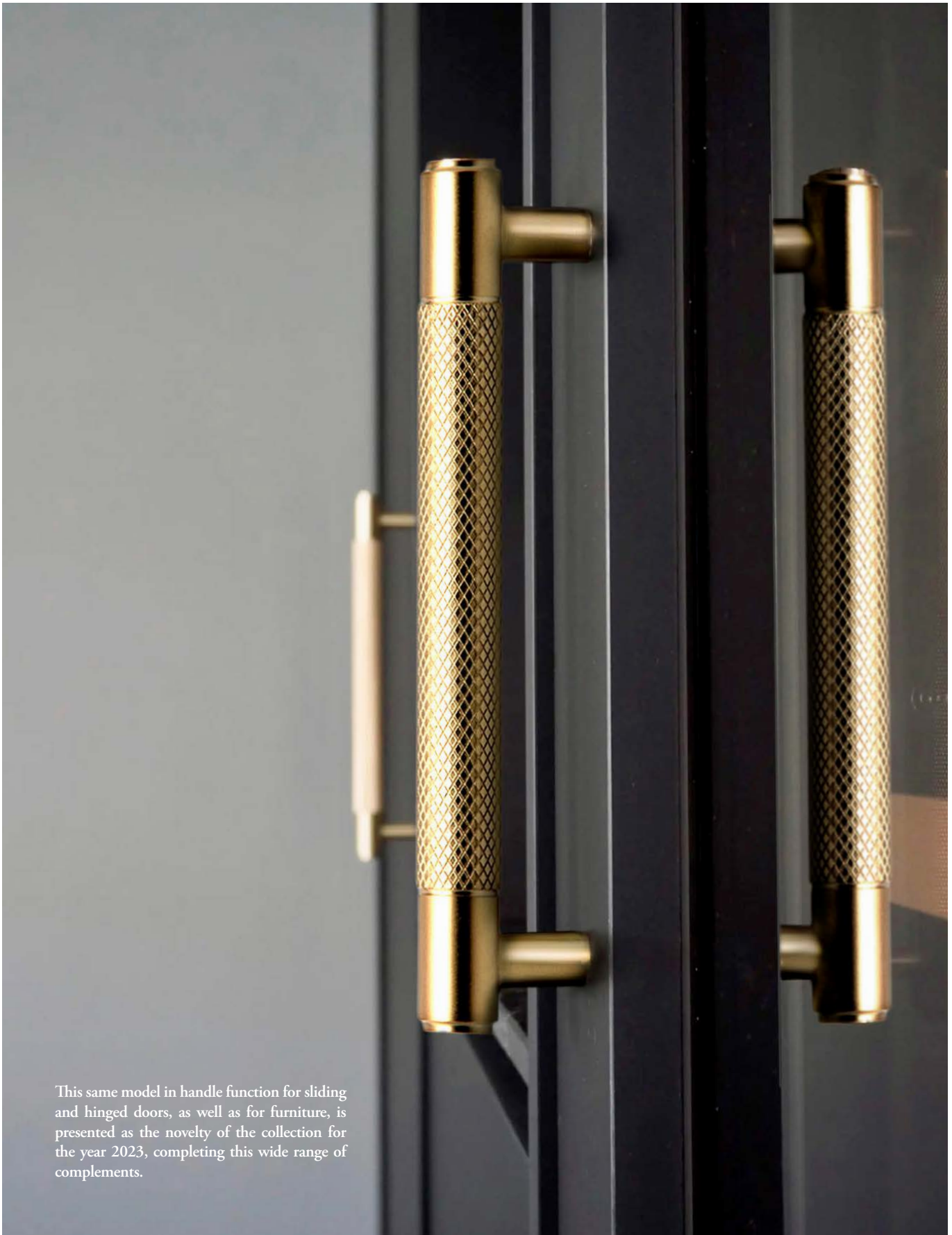

This same model in handle function for sliding and hinged doors, as well as for furniture, is presented as the novelty of the collection for the year 2023, completing this wide range of complements.



LA FABBRICA

Finishes

POWERCOAT
PAINTED
CHROME
VARNISH



GROËL'S FINISHES

THIS IS HOW WE DO IT!

Welcome to **La Fabbrica Finishes**. This section is dedicated to explain in depth the technical properties of our finishes.





POWER COATING



WHAT IS POWERCOATING? ^(1,2)

This technique is commonly known as Physical Vapour Deposition (PVD). As demonstrated in the diagram (right), PVD is characterised by a vaporisation of a solid metal which is condensed back on the substrate as a thin layer. The process is carried out in a high vacuum chamber using a cathodic arc source. At Groël we vaporise titanium into an ionised plasma gas which gets adhered to our lever handles and accessories. Titanium nitride coatings, in addition to being beautiful, have the highest resistance to abrasion and corrosion and are used to cover products in constant contact with the hand.

WHAT ARE THE BENEFITS? ^(1,3)

Environmentally friendly. This method practically eradicates the use of toxic raw materials, chemical reactions, and disposal of chemicals.

Resistant. Offers the highest protection against corrosion, impact, high temperatures and saline environments.

High purity. The deposited film is in its purest state owing to the vacuum method that removes any unwanted element.

Antibacterial. Surgical medical devices undergo PVD as part of the manufacturing process to protect against bacteria attachment on the surface and the formation of biofilms and undesired infections.

BIBLIOGRAPHY

1. Zalnezhad E, Sarhan AAD. Fuzzy modeling to predict the adhesion strength of TiN ceramic thin film coating on aerospace AL7075-T6 alloy. In: Recent Advances in Structural Integrity Analysis - Proceedings of the International Congress (APCF/ SIF-2014). Elsevier; 2014. p. 239–44.
2. Shang SM, Zeng W. Conductive nanofibres and nanocoatings for smart textiles. In: Multidisciplinary Know-How for Smart-Textiles Developers. Elsevier; 2013. p. 92–128.
3. Benčina M, Resnik M, Starič P, Junkar I. Use of Plasma Technologies for Antibacterial Surface Properties of Metals. *Molecules*. 2021 Mar 5;26(5):1418.

PHYSICAL VAPOUR DEPOSITION DIAGRAM

Open your mind, and project yourself into a **better future.**

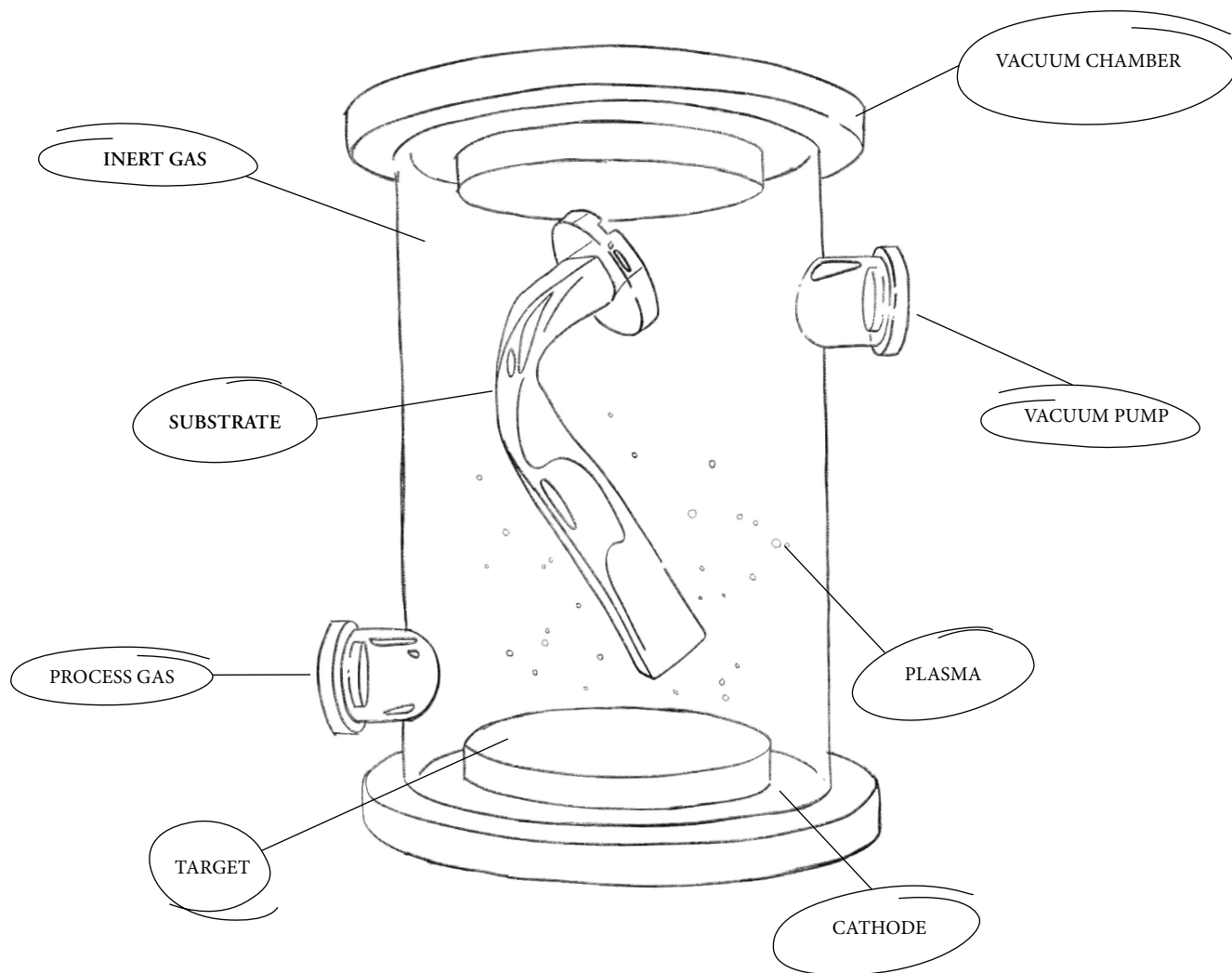

"This atom-to-atom deposition in PVD allows a precise control of density, stoichiometry and atomic structure of the thin film. By using the appropriate materials and creating special conditions during the coating process, coatings with desirable chemical properties such as hardness, lubricity and good adhesion can be created on the handle's surface."

Groël's Industrial Chemist

EPOXY PAINTED

PIONEERS IN MAT BLACK FINISHES

Our certified EPOXY lacquer is highly adherent and resistant to environmental agents (ISO 9227) and to UV radiation (EN ISO 13474-2 2014). We offer up to 15 years guarantee, the highest on the market. These ISO standards contribute to the following Sustainable Development Goals (SDGs) to address some of the most pressing issues faced by the world. The high quality of our palette selection will give a aesthetic touch to your selected model. Nonetheless, thanks to the great capacity of our facilities we encourage you encourage you to set your own ideas free, and together create your ideal tonality - what about pink?

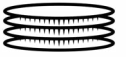

CHROME

III

Our ecologic trivalent chrome, Cr (III), finish grants a 15 years resistance warranty. Both satin and polished surface finishes are protected against corrosion and daily use. While chromium metal and Cr (III) ions are considered non-toxic, the commonly used hexavalent chromium Cr (VI), is toxic and carcinogenic. By 2030, it will be mandatory to use Cr (III); why wait? We picked the sustainable path in advance, complying with these SDGs goals. We are the first ones in promoting this high density, incredible durability and friendliness with the environment that Cr (III) offers.

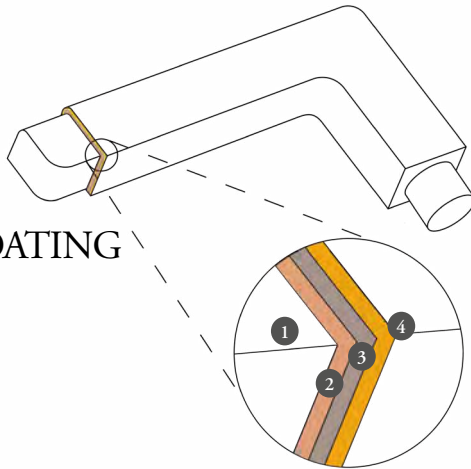

1. BRASS
2. ADHESIVE COATING
3. CHROME
4. POWERCOAT

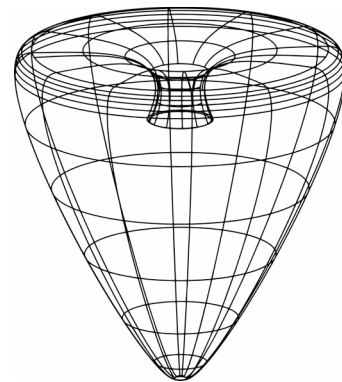

VARNISH

By using the latest generation's water varnishes we manage to enhance the beauty of our materials following the strictest sustainability standards. We use Catapgoresis, which is an anticorrosive method surface treatment for pure brass that manages uniform coating thickness over the entire surface including the hardest places to reach.



SUSTAINABLE
DEVELOPMENT
GOALS

ZÈRO

As you may have noticed throughout Groël's Foundation and La Fabbrica's sections, our production steps, packaging and modus operandi complies with European environmental legislation and regulations supporting a sustainable management model. Furthermore, we already joined the SDG goals set for 2030. The SDGs are 17 goals serving as a shared blueprint for prosperity for people and the planet now and into the future formulated in 2015 by the United Nations General Assembly.

Groël's Sustainability

ZÈRO HARMFUL EMISSIONS. ZÈRO TOXIC WASTE. ZÈRO ENVIRONMENTAL IMPACT.

All our products are made using creative handcrafted resources, and investing in the latest technology to optimise product's quality, and protect the environment.

For us, there is no quality without sustainability, and there is no good service without personal care.



THE SHARPEST DESIGN WITH
AVANT-GARDE ATTRIBUTES



THE INTRINSIC BEAUTY OF PERFECT
PYRAMIDAL AND GEOMETRICAL SHAPES



A COMPLETELY NEW AND
EVOLVED CONCEPTION



233

THREE

ONLY AVAILABLE IN OUR **WEBSITE**

ADVANCED
SILHOUETTE

CHROMED
TONALITIES

groël

ROUND
ROSE

RESISTANCE
TECHNOLOGIES

The pinnacle of design

BLACK AS THE ULTIMATE REPRESENTATIVE OF GLAMOUR.

It is no coincidence that the top representatives of fashion conceive of the colour black as essential in their designs. To illustrate this thought by some notable examples, we can cite Gianni Versace, who said that "black is the quintessence of simplicity and elegance", as well as Yves Saint Laurent who stated that "black symbolises the liaison of art and fashion". There is little more to add to these two premises, which so extol the value of this colour with so many different connotations.

Despite having been designated for centuries as a colour related to sobriety and mourning in Western society, from the 20th century onwards this trend took a turn and fashion designers began to consider that, within this sober shade of black, there is an unparalleled elegance and sophistication simply by changing fabrics and styles in clothing and fashion accessories. Plunging necklines, long mermaid tail dresses and short dresses like Coco Chanel's famous *petite robe noire*, sequins, velvet, satin, silk, crystals and a multitude of materials that had been used for colourful dresses reserved for a high net worth audience are becoming trends thanks to their use in black suits and accessories that are becoming more and more accessible to a wider public.

Nowadays, the colour black has gained strength in fashion and it is considered a basic for every item of clothing, a must in the wardrobes of anyone who follows the style trends of the moment thanks to its versatility, sobriety, sensuality, glamour and discretion. A colour that combines with everything, that can be the base of a canvas or the nuance that decorates it. However, black has gone beyond the barriers of fashion design and has adapted to other fields of design such as interior design.

Today, a multitude of styles are latent in society in terms of construction and interior design. The same architectural trend is no longer followed in a town, unless the aim is to maintain the style of the town itself, as is the case of the old quarter of Altea (Alicante), but architects now let their imagination run wild and capture their whims in new constructions or renovations, creating different atmospheres in the same city. In the same way, the interior design of a home, creativity comes to the fore and the most personal style of each individual can be seen. To this end, it is becoming more and more common to create semi-open spaces that avoid permanent construction elements and opt for decoration to the taste of its owner with elements that adapt easily to the environment.





GROËL'S EDITORIAL

Pioneers of black

The interior decoration accessories, far from being rococo and wanting to overload the environments, are dedicated to giving small touches of colour bringing warmth to the spaces, regardless of the tone that has been chosen. A must in the current trend in interior design is black. While light tones are used on walls, doors and ceilings to make rooms more spacious combined with mirrors and large windows to let in more natural light, accessories stand out for their colour and personality. Today's fashion and interior design accessories are characterised by their simplicity and minimalist style with the intention of not overloading spaces, but rather to give them a beauty that stands out for its elegance, harmony and modernity.

WRITTEN BY **Vanessa RUIZ**



And within the field of decoration, despite not being the first thing one thinks of when talking about interior design, lever handles are a must for the home and for any room, and when we talk about minimalism, simplicity, modernity, elegance and sophistication, we undoubtedly refer to the Baci model in matt black. Groël was the first handle manufacturer in the Mediterranean to opt for the colour black, applying a matt black finish to its lever handles almost ten years ago. With them, the avant-garde came to the doors of homes and other spaces becoming an essential & indispensable product, providing the characteristic design of the brand to each door in which it is installed. In addition, its versatility thanks to its design and colour adapts to every space and facilitates the insertion of other decorative elements in the same room without losing the harmony that we all seek in our daily lives.

Ristorante Classico, Brescia (Italy)

A project designed by Pelizzari Studio, using the Shift handle, from our Gestures Collection.



Duality

of design.



*AT GROËL, THROUGH OUR DESIGNS WE COMBINE TWO ADVERSE IDEAS
TO CONCEIVE A UNIQUE IDENTITY.*

Let's think about
**ART IN ITS PUREST
EXISTENCE**

In nature, there is an innate balance between opposing forces which are surprisingly complementary and connected to each other, composing perfect shapes.



Let's think now about
**DESIGN IN ITS MOST
ADVANCED APPROACH**

When duality is expressed between two concepts that manage to face each other in balance, then harmony is achieved and a new and evolved conception is created.

We merged traditional design with the latest trends to rescue the best of the two eras.

In the picture:

On the right side: VASILISA in MATT BLACK. The sharpest design of a cylindrical artful conception with a minimalist silhouette.

On the left side: VASILISA, in POLISHED BRASS. A design acknowledging tradition meticulously conceived with a romantic hint.





YIN YANG

Balance in art is one of the basic principles of design, along with contrast, movement, rhythm, emphasis, pattern, unity, and variety. Balance refers to how the elements of art (line, shape, colour, value, space, form, texture) relate to each other within the composition in terms of their visual weight to create visual equilibrium.

The Yin Yang is our approach to depict the great harmony found in the contrast between two concepts. The Yin Yang symbol itself does not feature a fully black side set against a fully white side: the white has a bit of black, and the black a bit of white. These interconnected antagonistic forces result in a powerful integrity. On our behalf, we make paradoxical

concepts flow in tune to become an independent compelling entity. By aiming the same target, they share a small part of their personality but without losing their individual remarkable essence.

The ancient Chinese philosophy of Yin and Yang recalls the duality in the universe. Today this concept is still present in natural occurrences and in our daily life as well as across cultures, architecture and interior design.

WRITTEN BY **María TORREGROSSA**
PRODUCT DESIGNER
Daniel TORREGROSSA

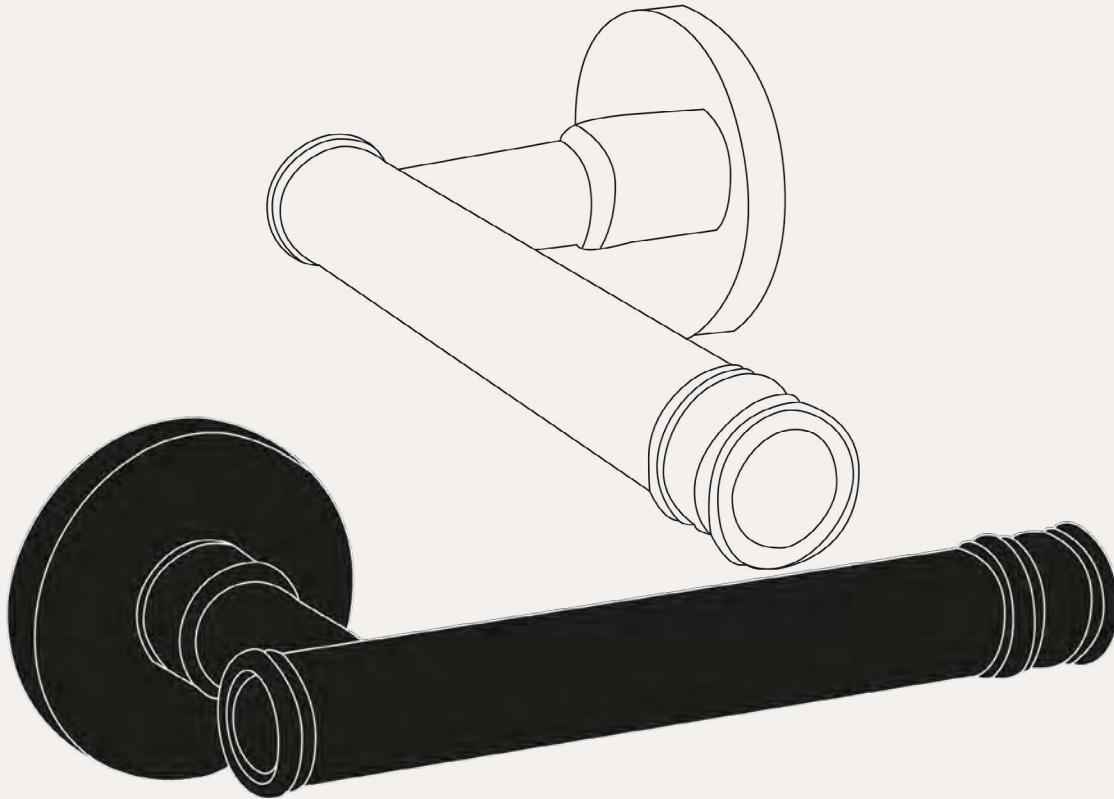

Yin Yang, the duality in design



This model emerges from a traditional design to join the latest trends and rescue the best of the two eras. **The Vasilisa model has caught the attention of architects pursuing romanticism and minimalism at the same time.** A cylindrical conception with delicate details on its grip. This design is very popular in its black matt black finish due to its transgressive aesthetic.

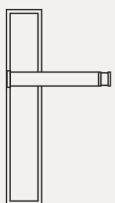

BACKPLATE
540PC2 VASILISA

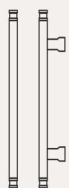

PULL HANDLE
540M VASILISA

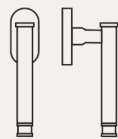

WINDOW HANDLE
540G VASILISA

Always made in pure brass, this design offers a full collection to create harmony in your projects. **Find out about the Vasilisa pull handle and Ducato knob as well as the accessories:** escutcheons, privacy turn and release, or even in different formats such as adapted for windows or on backplates.

groël
handle design



Elisabeth

A BRITISH-FLAVOURED PICTURESQUE COURTESY

PRESENT IN MORE THAN 35 COUNTRIES

Challenges are our passion and we turn them into adventures that end up being a dream come true.

At Groël, we began to specialise in the creation of lever handles and accessories in collaboration with interior designers, architects and prestigious designers whose needs demanded a special product

with high quality. Faced with the possibility of creating unique and personalised pieces, we decided to take the plunge. Thanks to our design and production team, we managed to meet the expectations of our partners and, in turn, their customers.

Thanks to the variety of our ranges and the versatility of our models, Groël's lever handles and accessories are present all over the world, in residential projects as well as in hotels, offices, restaurants, etc., helping each environment reach its maximum splendour.



LABORDE, PARIS (FRNACE).

Our Baci model is present at the new Gide headquarters, the leading international law firm in France. Modern minimalism, sober and elegance allied with la gentilezza di un Bacio.



JW MARRIOTT HOTEL, CANNES (FRANCE).

The modern, sophisticated and chic style of the rooms and suites of this hotel has been completed with the Art déco lever handle.

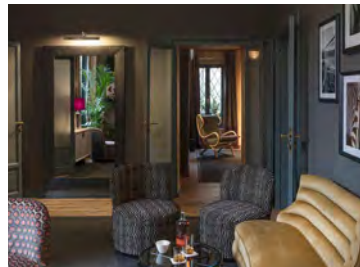
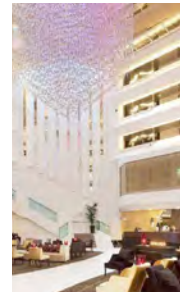

CLASSICO RISTORANTE, BRESCIA (ITALY).

A sophisticated dimension opens up and envelops us as we ascend the grand staircase of this 18th century palace, complemented by the Shift lever handle.

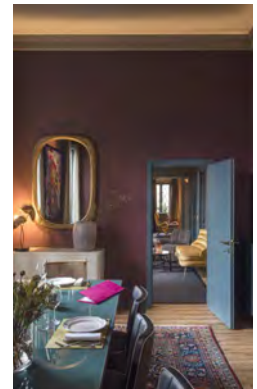

One of our most recent creations in collaboration with the well-known interior design Pellizzari Studio, the **Shift** lever handle, has been chosen for the Classico Ristorante in Brescia, Italy. A sophisticated dimension opens up and envelops us as we ascend the grand staircase of this 17th century palace with a cloister where this restaurant is located. Dark and warm colours will make guests feel comfortable from the first minute and will invite you to go back to this refinate and exclusive corner where Italian gastronomic tradition is surrounded by magic.

The versatility of our lever handles and the large number of designs we have created allow us to be present in a multitude of spaces. In fact, our **Log.gic** model is present at the new Gas Natural Fenosa's headquarters, located in a large twenty stories high glass tower which has become part of the new **Barcelona skyline**. However, on the opposite side, we find our **María** rustic model in a hotel designed with luxury and exclusivity in mind, the Alfonso XIII Hotel, featuring 126 rooms, 22 luxury suites and a royal suite, all exquisitely decorated in a Moorish, Andalusian and Castilian style.

**ALFONSO XIII,
A LUXURY COLLECTION HOTEL, SEVILLE (SPAIN).**

*This emblematic hotel features since its renovation the **María** lever handle.*



**HEADQUARTERS GAS NATURAL
FENOSA, BARCELONA (SPAIN).**

*It recreates a kind of large door opening to the neighborhood of **La Barceloneta**, fitting perfectly with the **Log.gic** lever handle.*



The lever handle is not an ordinary object; it's the harmonious connection between our hands and our home. Because any place can be a home if you want it to be.

GROËL'S PROJECTS



Cap Vermell Grand Hotel is a luxury resort that reflects the style of a traditional Mallorcan village located on the top of a hill, with references to local art and cultural heritage. Our Hélice lever handle is part of the decoration of the more than 100 suites of this resort belonging to the prestigious Cap Vermell Group hotel chain.

CAP VERMELL GRAND HOTEL, MAJORCA (SPAIN).

This luxury resort, surrounded by paradisiacal beaches and coves in the beautiful island of Majorca, features Hélice lever handle in Powercoat satin brass.



VILLA VOGUE, CAP D'ANTIBÈS (FRANCE).

For this luxury villa, the Palline lever handle was used with a design that, while not denying tradition, is capable of giving a rejuvenating touch to any space and ambience.

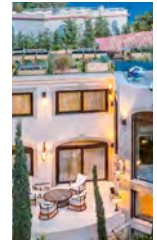

FOUR SEASONS HOTEL, NILE PLAZA (EGYPT).

This hotel surrounded by nature and with all the services for its guests, completed its stays with our beautiful Tendenza lever handle; also Malika, Sketch and Torso pull handle.



Who doesn't like to feel at home when being away from their own one? Harmony of styles, shapes and tones are essential in interior design and we want to contribute to this sensation of well-being. Interior designers and architects approach us with an idea, with a particular style and design and then, through an exhaustive study of the project and the idea presented to us, we turn their dreams into a reality. We create all sorts of accessories perfectly matching the lever handle design and the environment in which they are installed, because we firmly believe that beauty has the power to improve anyone's lifestyle. Every project we have had the pleasure of working on has required innovation and thoughtful planning that has resulted in a space full of life and beauty. All this, is added to the exquisite quality of our lever handles, specially created to fit in the most demanding projects all over the world. It is for this reason that Groël is present in offices, in private and

touristic villas, in hotels, in restaurants and in commercial premises. This is how Groël manages to give style, avant-garde and warmth to all the spaces where our lever handles and accessories are present, always in the right tone, with their usual delicacy but without going unnoticed. Our ability to adapt to any need and the fact that we are manufacturers gives us the possibility of creating and customising models with total freedom and originality to offer that unique product to designers and interior designers who wish to have a Groël in their projects.

PRESENT IN MORE THAN 35 COUNTRIES

The Nina lever handle has been chosen to complete the design of Al Rayyan's Ahmad Bin Ali Stadium. The most striking feature of this spectacular stadium is its resplendent façade, composed of motives that characterise different aspects of the country: the importance of the family, the beauty of the desert, the native flora and fauna, as well as local and international trade. The Nina model fits perfectly into this project thanks to the movement evoked by its undulating lines that correspond to those of the stadium structure.

The Hotel du Palais is a real gem located in Biarritz, just in front of the Atlantic Ocean. Built in 1854, the former residence of Napoleon III and Empress Eugenia, it was converted into a hotel in 1893, accommodating anyone who wants to feel like royalty and experience luxury and majesty. Our Touch model was the lever handle that was chosen for this project as it has a perfect design for sober environments to its strength and presence contrasting with the noble decorative delicacy of the rooms.



**AHMAD BIN ALI STADIUM,
AL-RAYYAN (QATAR).**

The Nina lever handle fits perfectly into this project thanks to the movement evoked by its undulating lines that correspond to those of the stadium structure.

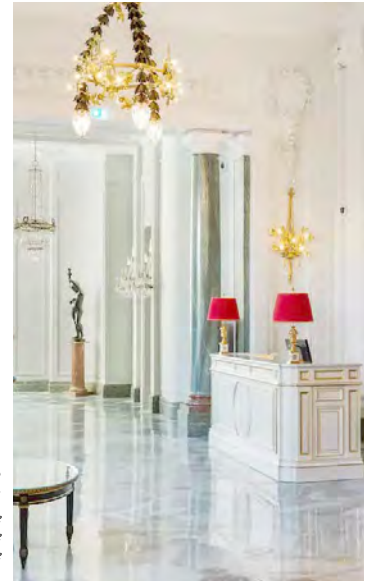

**HÔTEL DU PALAIS,
BIARRITZ (FRANCE).**

For this project, the chosen handle was our Touch lever handle design, contrasting with the noble decorative delicacy of the rooms.



**LJS RATXO ECO LUXURY
RETREAT, MAJORCA.**

To complete these wonderful rooms, the Bella model was selected one, a true classic that does not age, delicate and powerful at the same time thanks to its lovely combination of components, porcelain and brass.

Vision without action is a dream. Action without vision is simply passing the time. Action with vision is making a positive difference.

Joel Barker



GROËL'S FACTORY



FORGING

/ 1000°C

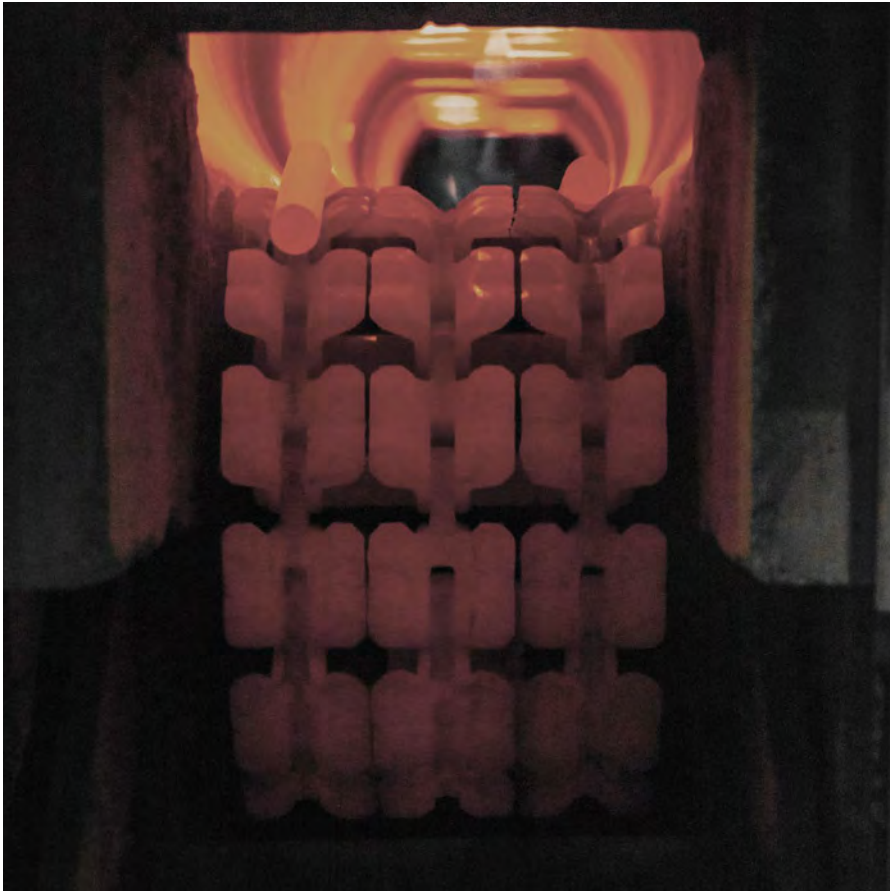

THIS IS OUR FORGING PROCESS. THE PURE BRASS BAR IS DIVIDED INTO SECTIONS AND HEATED TO AN EXHAUSTIVE TEMPERATURE OF 1000°C.

RAW MATERIAL

/ PURE BRASS



WE MAKE ALL OUR HANDLES EXCLUSIVELY OUT OF PURE BRASS BARS. OUR BRASS IS QUALIFIED AS PURE DUE TO ITS PROPERTIES AND USE OUTSIDE HARDWARE MANUFACTURING.

RAW MATERIAL

/ PURE BRASS

ANOTHER PROPERTY OF THIS BRASS IS ITS UNDOUBTED RESISTANCE. DUE TO THE PURITY OF ITS NATURE, IT REQUIRES THE MOST ADVANCED FOUNDRY TECHNOLOGY BECAUSE OF ITS ELEVATED MELTING POINT COMPARED TO CONVENTIONAL BRASS.

STAMPING

/ 975 PRESSURE IN TONS



THE INCANDESCENT BAR IS BENT AND STAMPED WITH 975 TONS BY SQUARED CENTIMETER.

STAMPING

/ 150 PIECES PER HOUR



THROUGH THIS AUTOMATED PROCESS WE MANAGE TO PRODUCE 150 PIECES PER HOUR.

MACHINING



THIS PROCESS IS WHAT ENABLES THE HANDLE TO BE SET ON A DOOR.

/ MULTITENSOR MEASURING MACHINE



WE CARRY OUT MACHINING BY COMPUTERISED MECHANICAL CONTROL, WHERE COMPUTERS ARE USED TO CONTROL THE MOVEMENT, OPERATION, AND SECURE A QUALITY STANDARD.

QUALITY WORK IS NEVER AN ACCIDENT

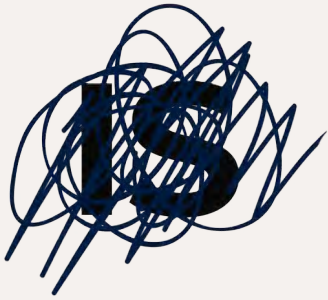

GRINDING &
MANUAL GRINDING



POLISHED



This important process is used to finish workpieces that must show high surface quality and high accuracy of shape and dimension. Grinding is executed with an abrasive wheel which cuts small chips from the handle to even out the surface of it. In the quality control, when requirements are not met, our specialists come into play to bring their expertise and manually adjust it.

Polishing gives a higher strength to the end product compared to their unpolished counterparts owing to the removal of stress concentrations present in the rough surface. In this phase every surface, edge and angle is softened giving a shiny, smooth and harmonious look to the design. This phase is also manually controlled to provide a flawless product. If the product doesn't meet the requirements and fails the control it goes through the polishing process again.

SATIN



Surprisingly, always on a perfectly polished surface is when we satin. This gives an aesthetic matt finish which is very pleasant to the sight and touch. You can find Groël's models in a variety of tonalities from satin brass to satin chrome or graphite.



First concept,
then design.



WELCOME TO GROËL'S UNIVERSE

The Groël family opens the doors to its home through the publication of this magazine. You will find out about the beauty of designing handles and accessories, the company's beginnings, philosophy, and accomplishments. This is the first ever handle design magazine in the world! The creativity, enthusiasm and determination of a young team has led to the creation of this magazine with a unique intention: setting a trend. The aim of this magazine is to demonstrate that Groël's design is interrelated with everything, from fashion to interior design, from an experience to a finished project, and from nature to a new product. What began as a dream became a reality when Groël produced its first handles and accessories. The ambition, clear vision and desire to progress led Groël to establish numerous collaborations with interior design and architecture studios around the world, which today is one of its major assets.



Quality, beauty, design, and ingenuity: JOIN GROËL'S UNIVERSE.

